

AN7222N

AM Tuner, FM-AM IF Amplifier

■ Description

The AN7222N is a monolithic integrated circuit designed for high performance, multi-function FM-AM IF system of low voltage operation.

■ Features

- Wide operation voltage ($V_{CC} = 2.8 \sim 9.6V$)
- Built-in detectors for both FM and AM
- Built-in level meter output (for both FM and AM)
- High sensitivity for AM owing to RF amplifier
- Low power consumption
- AFC control terminal
- Fewer external components

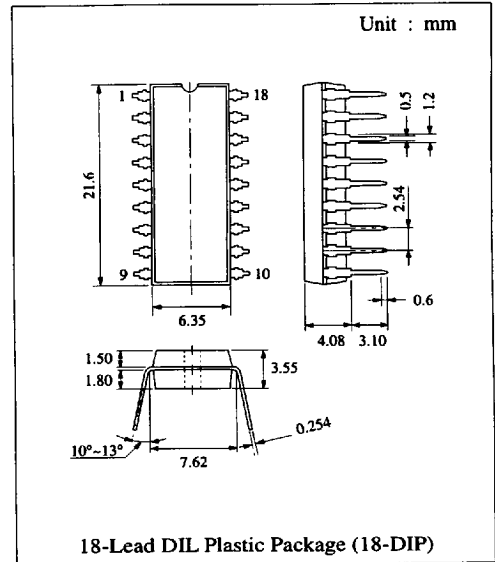

■ Block Diagram

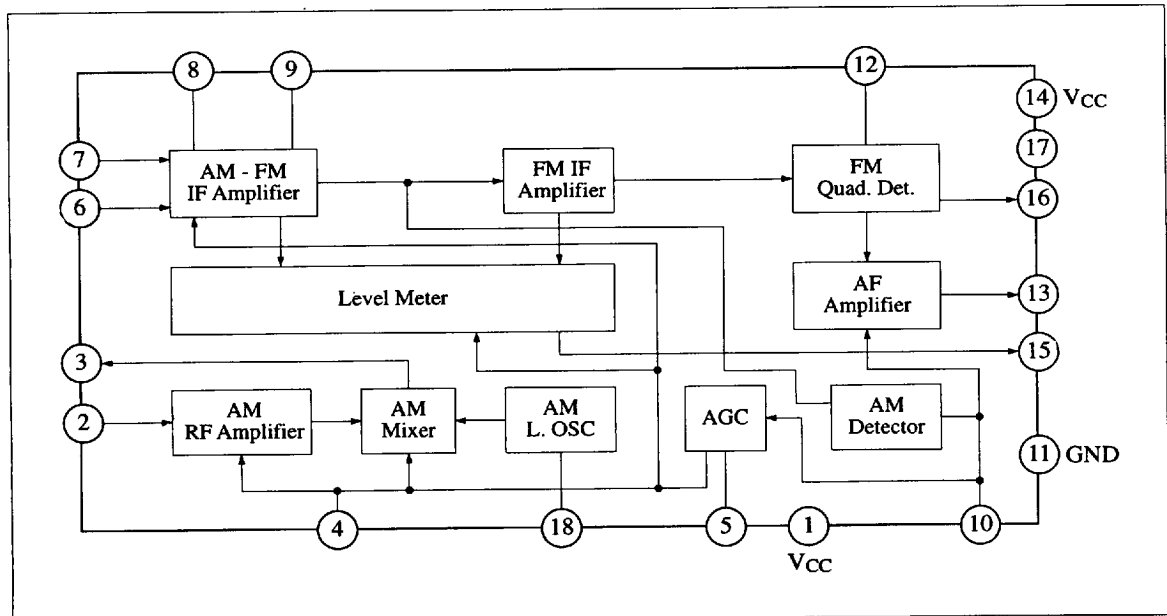

■ 6932852 0013862 0T0 ■

Panasonic

■ Absolute Maximum Ratings (Ta=25°C)

Item	Symbol	Rating	Unit
Supply Voltage	V _{CC}	9.6	V
Supply Current	I _{CC}	20	mA
Power Dissipation	P _D	192	mW
Operating Ambient Temperature	T _{opr}	-20 ~ +75	°C
Storage Temperature	T _{stg}	-55 ~ +150	°C

Operating Supply Voltage Range: V_{CC} = 2.8V ~ 9.6V

■ Electrical Characteristics (V_{CC}=5V, Ta=25°C)

Item		Symbol	Condition	min.	typ.	max.	Unit
F M	Detector Output Voltage	V _{O(FM)}	Input = 100dB	45	60	72	mV
	Limiting Sensitivity	V _{in(lim)}	Measure V _{in} at V _O -3dB	41	44	47	dBμ
	Meter Output Voltage (1)	V ₁₅₋₁₁	Input = 60dB	150	450	750	mV
	Meter Output Voltage (2)	V ₁₅₋₁₁	Input = 100dB	970	1100	1250	mV
	Offset Voltage	V ₁₆₋₁₇	Input = 0dB	-250	0	250	mV
A M	Detector Output Voltage	V _{O(AM)}	Input = 60dB	45	58	70	mV
	Sensitivity	S _(AM)	Measure V _{in} at V _O = 10mV	8.5	14	19.5	dBμ

Note : FM: f = 10.7MHz, f_{dev} = 22.5kHz, f_m = 400Hz

AM: f = 1MHz, f_m = 400Hz, Mod. = 30%

■ Pin

Pin No.	Pin Name	Pin No.	Pin Name
1	V _{CC} (AM)	10	AM Detector Output
2	AM RF Amplifier Input	11	GND
3	AM Mixer Output	12	FM Detector Coil
4	AGC Output (2)	13	AF Output
5	AGC Output (1)	14	V _{CC}
6	AM IF Amplifier Input	15	Level Meter Output
7	FM IF Amplifier Input	16	AFC Output
8	IF By-pass	17	Reference Voltage
9	IF By-pass	18	Local Oscillator Coil

Test Circuit

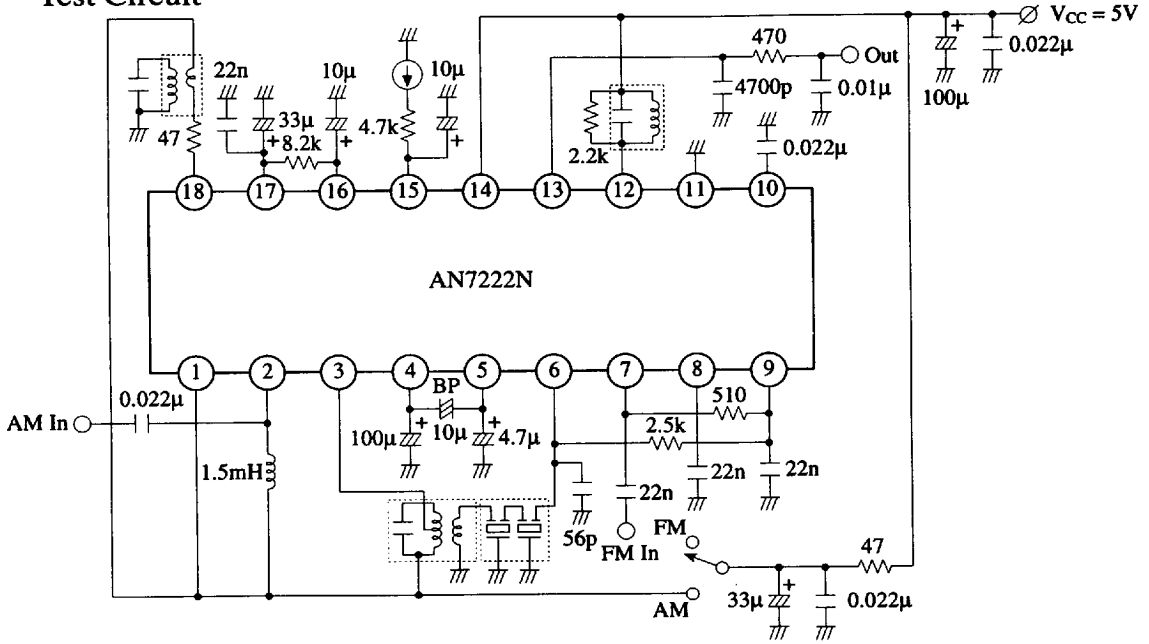

■ Application Circuit

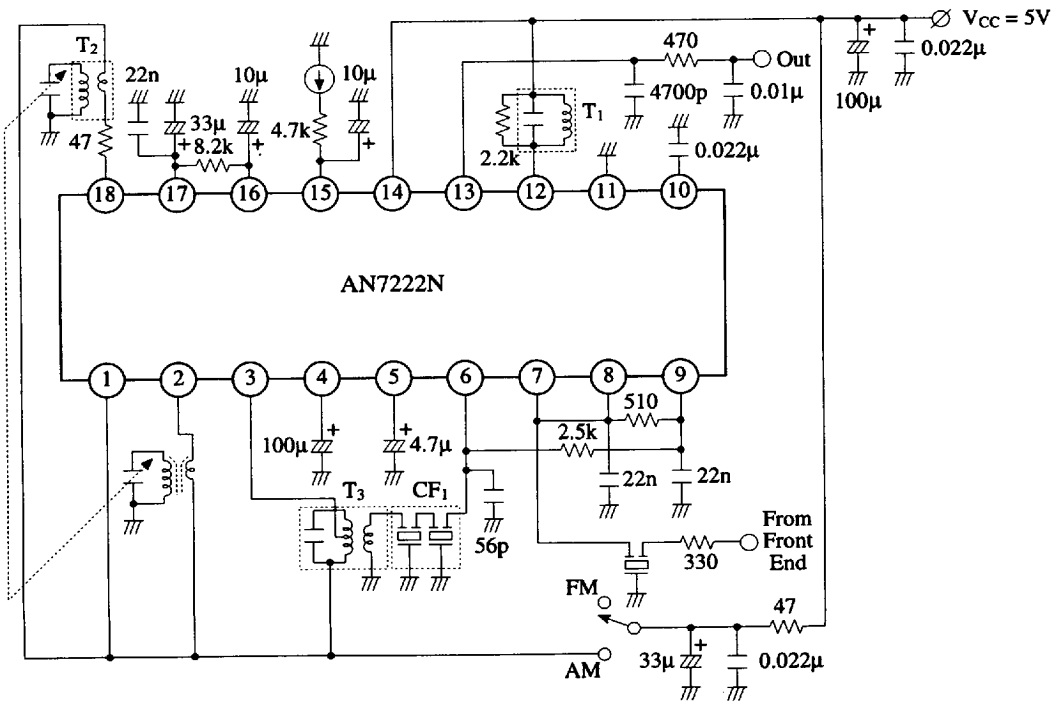

■ 6932852 0013864 973 ■

■ Coil Specifications

Symbol	Use, Freq.	Type No.	Maker	Connection Diagram	Number of Turns	Tuning Cap.	Unloaded Q
T ₁	FM Quad Coil 10.7MHz	EIF-7S752A	Matsushita		①...② 8T ②...③ 5T ④...⑥ 3T	100pF	90±20%
T ₂	AM MW Osc. Coil	ELL-7S754	Matsushita		①...② 4T ②...③ 125T ④...⑥ 7T	-	95±20%
T ₃	AM Mixer Output 455kHz	EIA-7S802A	Matsushita		③...② 35T ⑥...④ 10T ②...① 19T	1500pF	60±30%

■ Ceramic Filter Specification

Symbol	Use	Type No.	Maker	Center Freq.	Band Width	Loss
CF ₁	AM IF	CFM2-455B	Toko	455Hz	7kHz (-6dB)	2.6dB

■ Characteristics Curve

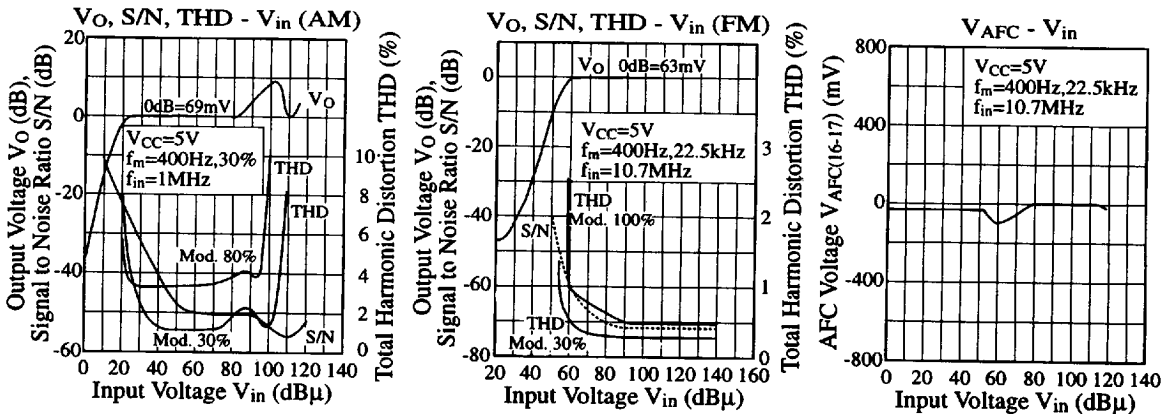

■ Characteristics Curve (Continue)

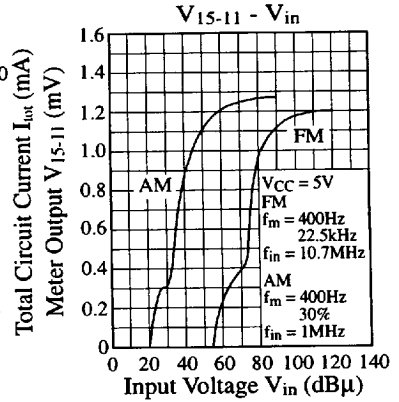
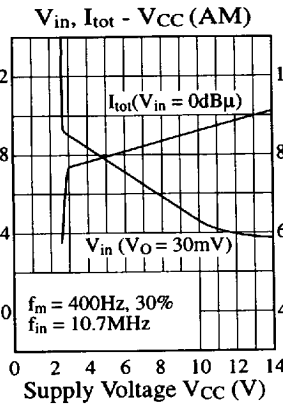
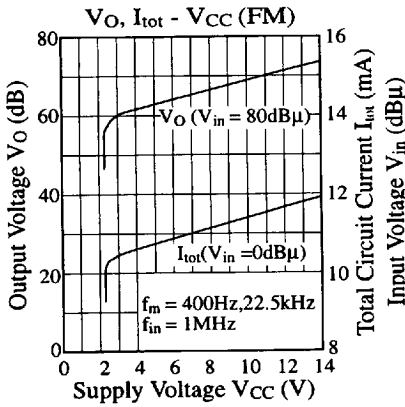
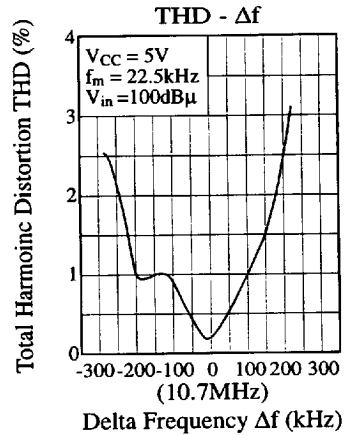
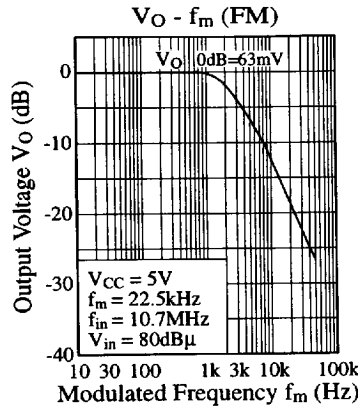
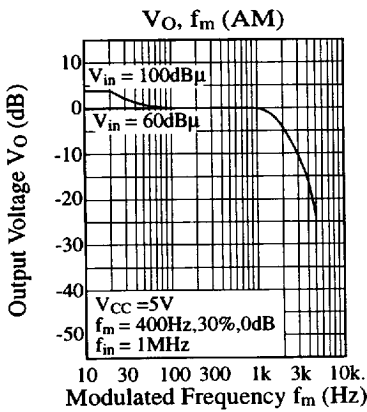

■ Printed Circuit Board Layout (Scale: 1:1)

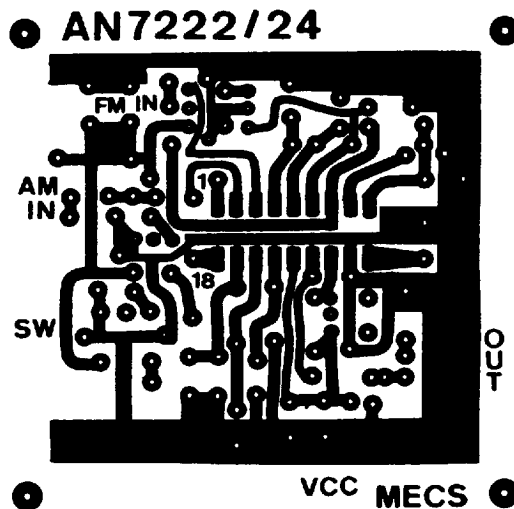

■ 6932852 0013866 746 ■