

## GNL-10003xx ( 10mm ROUND TYPE) Ultra Brightness

ABSOLUTE MAXIMUM RATING:(Ta=25 )

Parameter			Unit
DC Forward Current	30		mA
Reverse Voltage	5		V
Reverse Current (Vr=5V)	10		μA
Peak Forward Current ,tw ,=1 msec Duty ,=1/20	150		mA
Operation Temperature	-40	+80	
Storage Temperature	-40	+100	
Solder Dip (5 seconds,1.6mm from body ) Temperature	300	± 5	

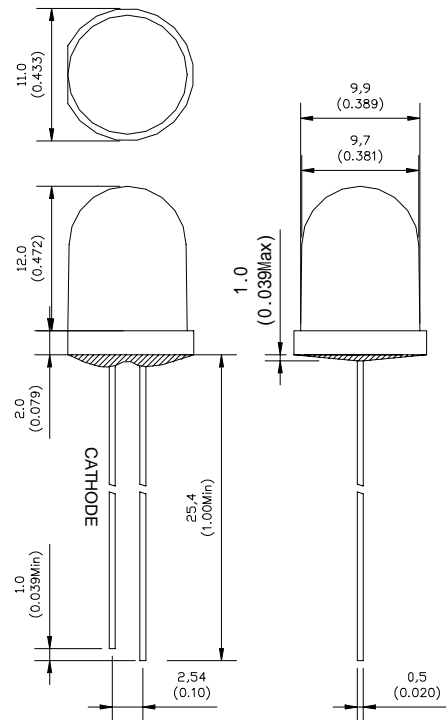

### Feature:

- 1.Small flange without stand-off
- 2.Long life-solid state reliability
- 3.Long lead length(25.4mm)
- 4.Versatile mounting on P.C. board or panel

### Description:

- 1.The shape of this series is round
- 2.General application is for indication,illumination,etc.
- 3.These LED lamps are available with a choice of defferent colors,light intensities,epoxy colors,etc.

Part Number	EMITTED COLOR		Lens Color	Peak Wavelength (nm)	Vf (v) Typ.	IV (If=20mA) mcd		View Angle 2 1/2
						Min.	Typ.	
GNL-10003UEC-TL	AlGaInP	Super Orange Red	Water Clear	625	2.0	2500	3500	20 °
GNL-10003UEC/B510-TL	AlGaInP	Super Orange Red	Water Clear	625	2.0	4500	5500	20 °
GNL-10003UYC-TL	AlGaInP	Super Yellow	Water Clear	590	2.0	3000	3500	20 °
GNL-10003UYC/B310-TL	AlGaInP	Super Yellow	Water Clear	590	2.0	4500	5500	20 °
GNL-10003UBC-TL	InGaN	Ultra Super Blue	Water Clear	470	3.5	4000	5000	20 °
GNL-10003BGC-TL	InGaN	Super Bluish Green	Water Clear	505	3.5	5000	6000	20 °
GNL-10003PGC-TL	InGaN	Super Pure Green	Water Clear	525	3.5	8000	9000	20 °
GNL-10003UWC-TL	InGaN	Ultra Super White	Water Clear	5500K-7000K	3.5	4500	5500	20 °