



ISO9001-2008  
Certificate No:02411Q20838R2M

CAREFUL環境關聯物質管控標準: Cd<5ppm; Pb<50ppm; Hg:ND; Cr6+:ND

Defer to: **SONY/SS-00259** ; SAMSUNG/OQA-2049 ; **MICROSOFT/H00594** ; FOXCONN/EPI12 ; **HP/HX-00011-00...**

# 承 認 書

## SPECIFICATION FOR APPROVAL

客户名稱 CUSTOMER	Radiomag Ukraine LLC
品名規格 DESCRIPTION	F9 SCRC 90A
客户料號 CUS. P/N	
提出日期 DATE	Mar.16. 2018.
編 號 SERIAL NO.	KF 18031626023

出 圖 DRAWING			承 認 CUSTOMER APPROVE	
發行 MADE	復 核 CHECKED	確 認 APPROVED		
DATE: 2018年03月16日				



科峰集團

CAREFUL GROUP

www.careful.cn  
e sales@careful.cn  
e info@careful.cn

湖州科峰磁業有限公司  
HuZhou Careful Magnetism Co.,Ltd.

浙江省湖州市含山工業區 313014  
Hanshan Industry Zone Huzhou Zhejiang

TEL: 00 86 - 572 - 367 0006 / 367 2766  
TEL: 00 86 - 572 - 367 0006 / 367 2766

FAX: 00 86 - 572 - 367 0025  
FAX: 00 86 - 572 - 367 0025

嘉興科峰磁電有限公司  
JiaXing Careful Magnetism & Electron Co.,Ltd.

浙江省嘉興市河山工業區 314512  
Heshan Industry Zone Jiaying Zhejiang

TEL: 00 86 - 573 - 8867 1616 / 8867 0988  
TEL: 00 86 - 573 - 8867 1616 / 8867 0988

FAX: 00 86 - 573 - 8867 1515  
FAX: 00 86 - 573 - 8867 1515

# 承 認 書

## SPECIFICATION FOR APPROVAL

客戶名稱 CUSTOMER	Radiomag Ukraine LLC	日期 DATE	2018.03.16.																
規 格 ITEM	F9 SCRC 90 A	編 號 SERIAL NO.	KF 18031626023																
<p>1.1. 形狀尺寸(單位/毫米): SHAPE &amp; DIMENSION(unit/mm):</p> <p>1.2. 實物圖: The Sample::</p>		<table border="1" style="width: 100%; border-collapse: collapse;"> <tr><td>A</td><td>36.0 ± 1.0 mm</td></tr> <tr><td>B</td><td>32.0 ± 1.0 mm</td></tr> <tr><td>C</td><td>9.0 ± 1.0 mm</td></tr> <tr><td>D</td><td>19.5 ± 1.0 mm</td></tr> <tr><td>E</td><td>16 ± 0.5 mm</td></tr> <tr><td>F</td><td>28.2 ± 0.7 mm</td></tr> <tr><td>G</td><td>9 ± 0.4 mm</td></tr> <tr><td>H</td><td></td></tr> </table>		A	36.0 ± 1.0 mm	B	32.0 ± 1.0 mm	C	9.0 ± 1.0 mm	D	19.5 ± 1.0 mm	E	16 ± 0.5 mm	F	28.2 ± 0.7 mm	G	9 ± 0.4 mm	H	
A	36.0 ± 1.0 mm																		
B	32.0 ± 1.0 mm																		
C	9.0 ± 1.0 mm																		
D	19.5 ± 1.0 mm																		
E	16 ± 0.5 mm																		
F	28.2 ± 0.7 mm																		
G	9 ± 0.4 mm																		
H																			
<p>外殼尺寸: ΦC(Core ID)</p>  <p>磁芯尺寸:</p>  																			
<p>2. 電氣性能檢測項目: ELECTRICAL REQUIREMENTS:</p>		<p>測試儀器 TEST INSTRUMENTS</p>																	
<input type="checkbox"/> L		TEST FREQ	KHZ MHZ																
<input type="checkbox"/> Q		TEST FREQ	KHZ MHZ																
<input checked="" type="checkbox"/> Z	Z1= 65Ω MIN	KHZ 25MHZ	Z2=125Ω MIN																
	Z3= /	KHZ MHZ	Z4= /																
溫度 TEMP	℃	濕 度 HUMIDITY	%																
線 組 WINDING	Φ0.5x0.5TSx100L(mm)																		
<p>3. 磁 芯 外 觀: THE LIMIT OF CORE BREAKAGE:</p>																			
<table border="1" style="width: 100%; border-collapse: collapse;"> <thead> <tr> <th style="text-align: center;">項 目 Item</th> <th style="text-align: center;">標 準 值 Standard Value</th> </tr> </thead> <tbody> <tr> <td>一處缺陷的面積 Area of a breakage</td> <td style="text-align: center;">≤1mm<sup>2</sup></td> </tr> <tr> <td>總缺陷面積 All area of the breakage</td> <td style="text-align: center;">≤2mm<sup>2</sup></td> </tr> <tr> <td>缺陷深度 The depth of the breakage</td> <td style="text-align: center;">≤0.4mm</td> </tr> <tr> <td>毛刺長度 The length of burr</td> <td style="text-align: center;">≤0.2mm</td> </tr> </tbody> </table>		項 目 Item	標 準 值 Standard Value	一處缺陷的面積 Area of a breakage	≤1mm <sup>2</sup>	總缺陷面積 All area of the breakage	≤2mm <sup>2</sup>	缺陷深度 The depth of the breakage	≤0.4mm	毛刺長度 The length of burr	≤0.2mm								
項 目 Item	標 準 值 Standard Value																		
一處缺陷的面積 Area of a breakage	≤1mm <sup>2</sup>																		
總缺陷面積 All area of the breakage	≤2mm <sup>2</sup>																		
缺陷深度 The depth of the breakage	≤0.4mm																		
毛刺長度 The length of burr	≤0.2mm																		
<p>4. 包 裝: PACKAGING:</p> <p>內包裝採用泡塑盒, 外包裝採用紙箱, 每箱產品外面都蓋上合格章(包括品名、數量、批號、檢驗員)。 Inner packing adopts foam plastics box, outer packing adopts carton and each carton should have a qualified chapter label outside(include the variety, quantity, batch number and inspector).</p>																			

A	首版First Edition	2018-03-16	Rosie
版本Rev.	變更內容說明Description of Change	日期Date	姓名Name

# 檢驗數據

## INSPECTION DATA

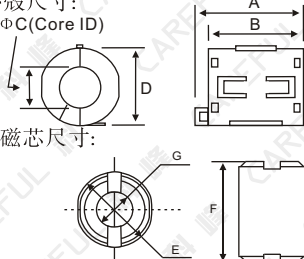
客戶名稱 CUSTOMER	Radiomag Ukraine LLC		日期 DATE	2018.03.16.	數量 QUANTITY	10PCS
編號 SERIAL NO.	KF 18031626023		形狀尺寸(單位/毫米): SHAPE & DIMENSION(unit/mm):		實物圖: The Sample:::	
規格 ITEM	F9 SCRC 90 A		外殼尺寸: ΦC(Core ID)			
線組 WINDING	Φ0.5x0.5TSx100L(mm)					
測試頻率 TEST FREQ	Z1=	KHZ 25 MHZ	Z2=	KHZ 100 MHZ		
	Z3=	KHZ MHZ	Z4=	KHZ MHZ		
溫度 TEMP	℃	濕度 HUMIDITY	%			

項目 TEST ITEM	電氣性能 ELECTRIC CHARACTERISTICS				尺寸(單位:毫米) DIMENSION(unit:mm)							
	L(μH) (MH)	Z1(Ω)	Z2(Ω)	Z3(Ω)	Z4(Ω)	A	B	C	D	E	F	G
		65	125			36.0	32.0	9.0	19.5	16	28.2	9
+	/	/				1.0	1.0	1.0	1.0	0.5	0.7	0.4
-	0	0				1.0	1.0	1.0	1.0	0.5	0.7	0.4
1		88.2	165.6			35.60	31.40	8.90	20.10	15.70	28.08	8.68
2		87.6	166.0			35.70	31.30	8.93	19.90	15.60	28.06	8.66
3		88.8	166.2			35.40	31.50	8.96	20.05	15.57	28.14	8.81
4		90.4	165.8			35.50	31.36	8.99	20.06	15.69	28.15	8.74
5		89.0	166.4			35.56	31.42	8.98	19.99	15.62	28.09	8.69
6		89.8	165.6			35.48	31.39	8.95	19.96	15.63	28.06	8.75
7		90.6	165.7			35.69	31.44	8.92	20.04	15.64	28.04	8.71
8		89.2	166.3			35.52	31.52	8.91	20.01	15.68	28.11	8.78
9		89.4	165.8			35.58	31.38	8.94	20.07	15.59	28.13	8.77
10		90.0	166.0			35.47	31.47	8.97	19.98	15.67	28.05	9.73
$\bar{X}$		89.30	165.94			35.55	31.41	8.94	20.01	15.63	28.09	8.73
Y/N	Y					Y	Y	Y	Y	Y	Y	Y

測試儀器:  
TEST INSTRUMENTS:

E4991A+16194A

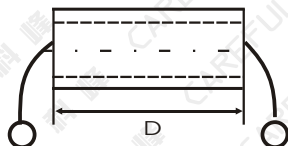

檢驗 INSPECTED	復核 CHECKED	確認 APPROVED
汪建琴	周紀君	沈學泉

A	首版First Edition	2018-03-16	Rosie
版本Rev.	變更內容說明Description of Change	日期Date	姓名Name

# 阻抗 - 頻率曲綫

## IMPEDANCE V.S FREQUENCY (Z-Y)

客戶名稱 CUSTOMER	Radiomag Ukraine LLC	日期 DATE	2018.03.16.
規格 ITEM	F9 SCRC 90 A	編號 SERIAL NO.	KF 18031626023

### 材質特性 MATERIAL CHARACTERISTICS

材料牌號 Material	初始磁導率 Initial Permeability	比損耗因子 Relative Loss Factor	比溫度系數 Relative Temperature Coefficient	飽和磁通密度 Saturation Magnetic Flux Density	剩磁 Remanence	矯頑力 Coercivity	居裏溫度 Curie Temperature	電阻率 Electrical Resistivity	密度 Density
Unit symbol	$\mu_i$ $\pm 20\%$	$\tan \delta / \mu_i$ $\times 10^{-6}$	$\alpha \mu_i / \gamma$ $\times 10^{-6}$	Bs (MT)	Br (MT)	HC (A/m)	Tc (°C)	$\rho$ ( $\Omega \cdot m$ )	d (g/cm <sup>3</sup> )
F9	850	16 (0.1MHz)	5 - 10	280(1600A/m)	200	20	>130	>10 <sup>5</sup>	4.6

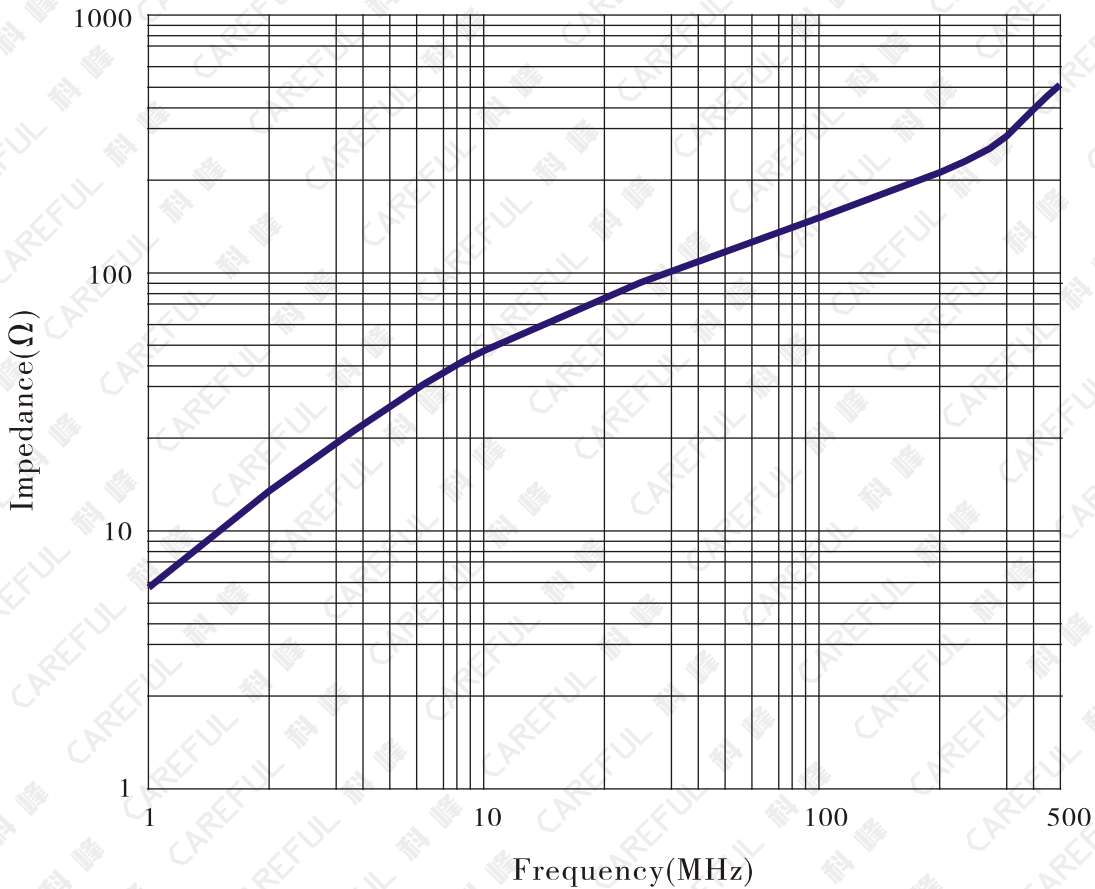

測試條件:  
TESTING CONDITION:

- 測試儀器: E4991A+16194A  
Testing Equipment:
- 測試頻率區間: 1-500MHz  
Testing Frequency Range:
- 測試綫組:  $\Phi 0.5 \times 0.5 \text{TS} \times 100 \text{L}(\text{mm})$   
Testing Coil Specification:

測試 TESTED	復核 CHECKED	確認 APPROVED
汪建琴	沈学泉	周纪君

A	首版First Edition	2018-03-16	Rosie
版本Rev.	變更內容說明Description of Change	日期Date	姓名Name