



Preliminary

# SPECIFICATION

Main Internal      Antenna

Part No. :      CTI-AMMAP003

June 24, 2009

#### Notes

The contents of this data sheet are subject to change without notice. Please confirm the specifications and delivery conditions when placing your order.

notice. Please

# 1. SPECIFICATIONS

## 1.1. Electrical Specifications

ITEM	GSM850	GSM 900	DCS	PCS	UMTS
Frequency [MHz]	824~894	880~960	1710~1880	1850~1990	1920~2170
Peak Gain [dBi]	0.67	1.56	5.25	5.00	5.52
Eff.[%] @Min	53%	60%	81%	76%	77%
VSWR	3.0 : 1 max				
Polarization	Linear				
Azimuth Beam Pattern	Omni-directional				
Impedance	50 Ω				

These values are measured on the matched reference test board.

## 1.2 . Mechanical Specifications

Electrode	Silver	-
Dimensions (L x W x H)	24.0 x 5.5 x 4.4	mm
Operating Temperature	-35 ~ +85	

## 1.3 . Appearance and Dimensions



Unit : mm  
Tolerance : ±0.15

L(Length)	24.0
W(Width)	5.5
H(Height)	4.4

## 2. MEASUREMENT

### 2.1 . SET for Measurement

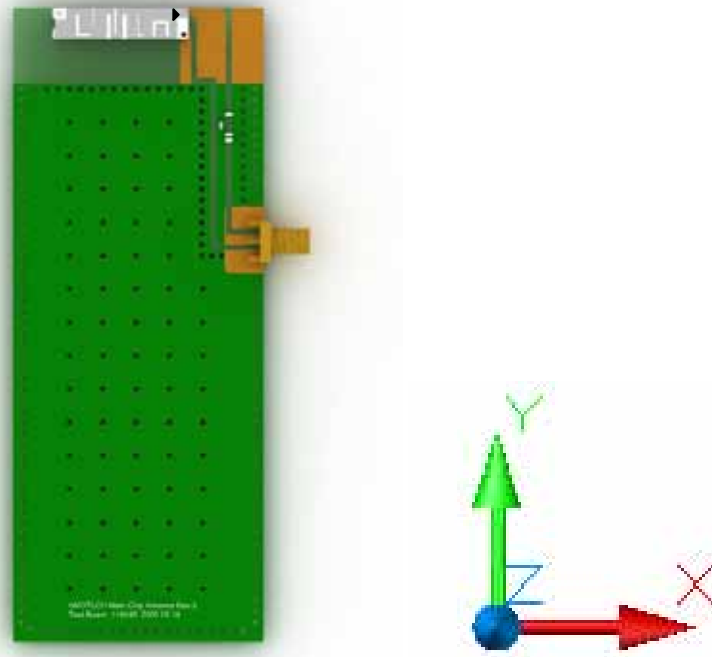

Board size: 114x45mm

Antenna Radiation the coordinate system

[X axis: the axis of rotation]

### 2. 2 . Electrical Characteristic

- Antenna matching on the reference test board

☒  $S_{11}$  (Return loss & VSWR )

Penta Band ( GSM 850 & 900 , DCS, PCS, UMTS)

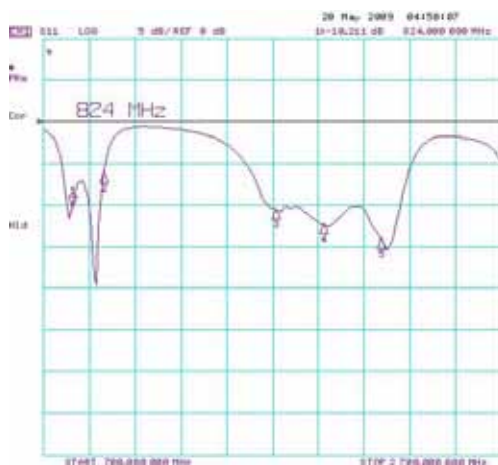

- Return loss -

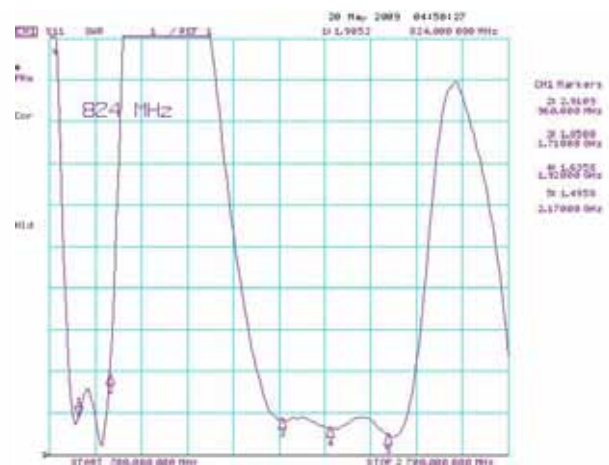

- SWR -

## 2. 3 . Radiation Characteristic

### - Measurement Setup

- 6mx3mx3m Anechoic Chamber
- Matching on the standard test board (114 x 45mm)
- Temp. : 25 / Humidity : 50~55%

### - Measurement Result

Band	Frequency MHz]	Ave. gain (dBi)	Peak. Gain (dBi)	Eff.(%)
GSM850	824	-2.73	-0.21	53.36
	849	-2.77	-0.51	54.37
	869	-2.74	-0.74	53.26
	894	-1.22	0.67	75.50
GSM900	880	-2.00	-0.11	63.06
	915	-0.50	1.42	89.16
	925	-0.49	1.56	89.37
	960	-2.22	0.58	60.03
DCS	1710	-0.12	4.98	97.24
	1785	-0.13	5.03	97.35
	1805	-0.28	5.25	93.84
	1880	-0.90	4.97	81.34
PCS	1850	-0.39	5.52	91.39
	1910	-1.03	4.97	78.90
	1930	-1.16	4.94	76.50
	1990	-0.80	4.98	83.12
UMTS	1920	-1.11	4.94	77.41
	1980	-0.94	5.00	80.51
	2110	-1.11	4.01	77.45
	2170	-0.12	4.71	97.24



### 3.2. Soldering Profile

Solder paste : Sn/Ag/Cu:96.5/3.0/0.5

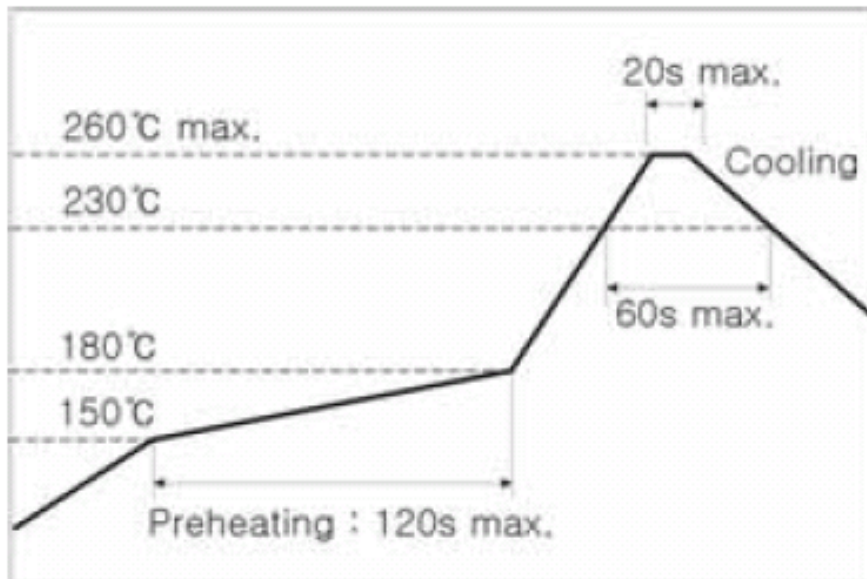

This product is designed for reflow soldering only. Do not use flow (wave) soldering.

- ① Use non-activated flux (Cl content 0.2% max.)
- ② Follow the recommended soldering conditions to avoid damage.
- ③ Reflow-cycle is max. 3 times.

# 4. A TTACHMENT

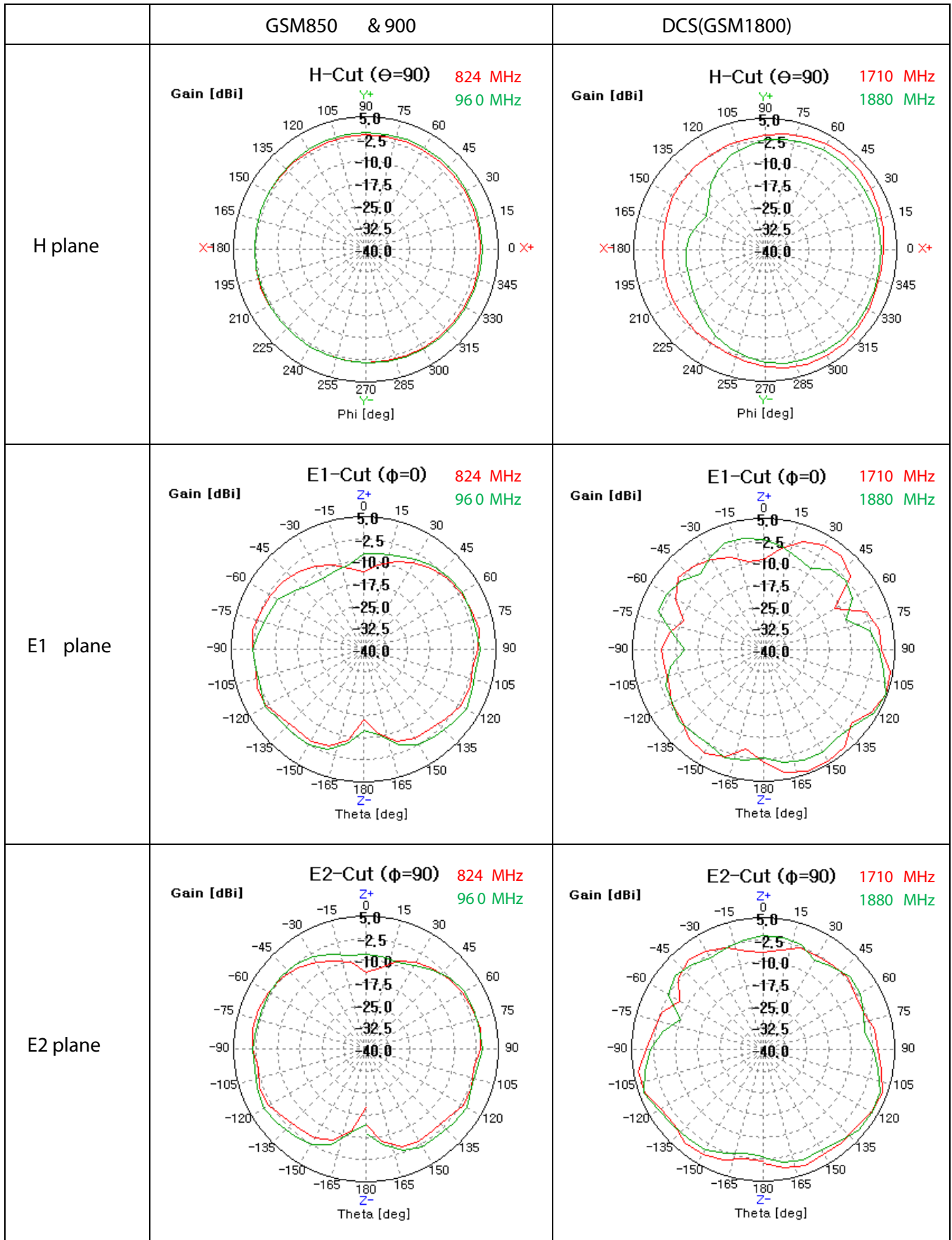

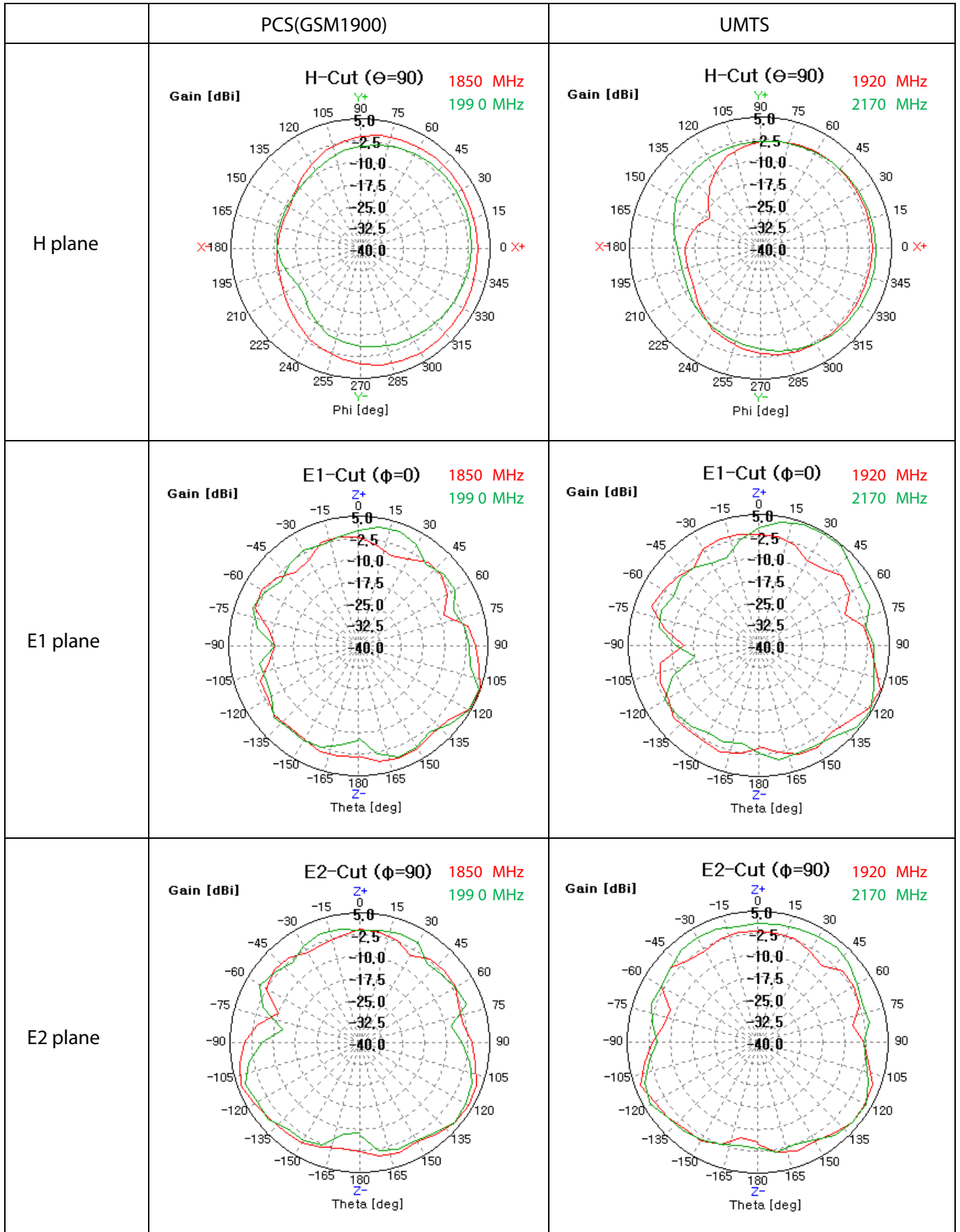



## 5. PACKING

### 5.1 Tape Dimension (unit : mm)

#### 5.1.1 Size

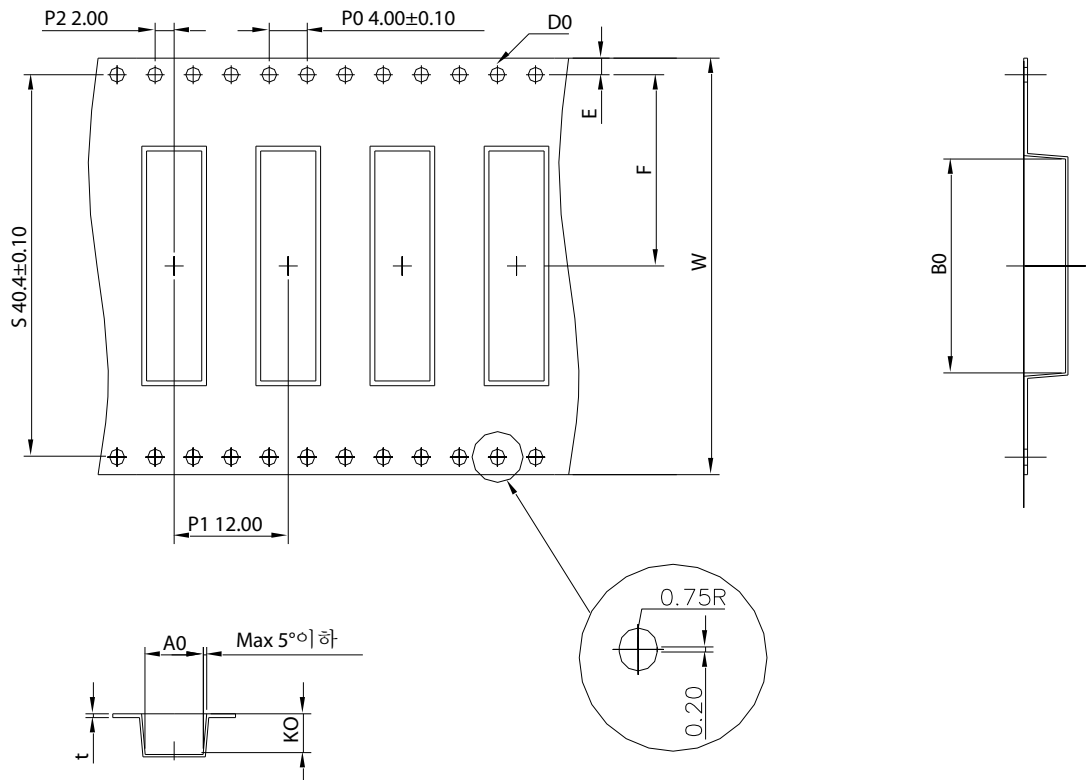

A0	5.80±0.20	E	1.75±0.10
B0	24.30±0.20	F	20.20±0.20
K0	4.60±0.20	W	44.00±0.30
D0	1.55±0.05	t	0.40±0.05

#### 5.1.2 Surface resistance

- 1) Carrier tape : Max  $10^{11}\Omega$
- 2) Cover tape : Max  $10^{11}\Omega$
- 3) Reel : Max  $10^{11}\Omega$

## 5.2 Description of Reel

### 5.2.1 Size

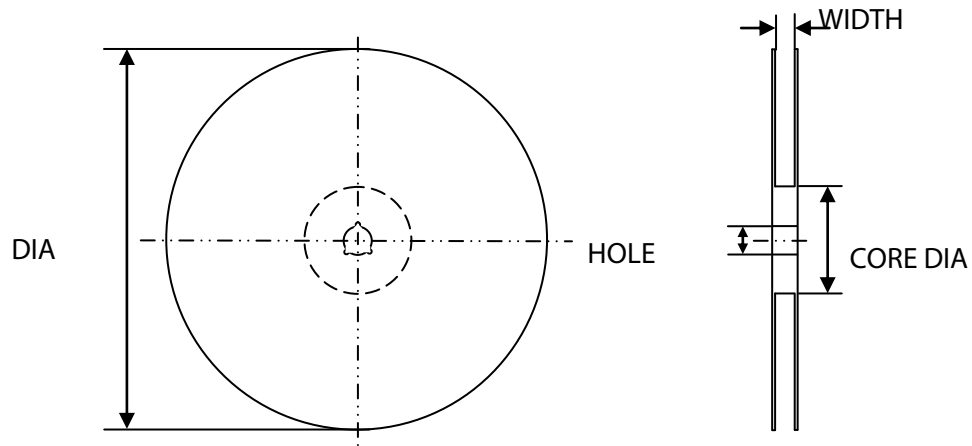

ITEM	DIA	WIDTH	CORE DIA	HOLE
Size(mm)	330.0 +0,-3	45.5 ± 0.3	100.0 ± 1	13.2 ± 0.5

### 5.2.2 Material

- 1) Plastic reel : GPPS (General Purpose Poly Styrene) resin

## 5.3 Description of Packing Box

### 5.3.1 Reel

Size : 44 (W), Dia.Φ330 (mm)

Quantity : 1,000 ea/reel

### 5.3.1 Inner Box

Size : 350 (W) x 345 (D) x 55 (T) (mm)

Quantity : 1 reel (1,000 ea/reel × 1 reel = 1,000 ea)

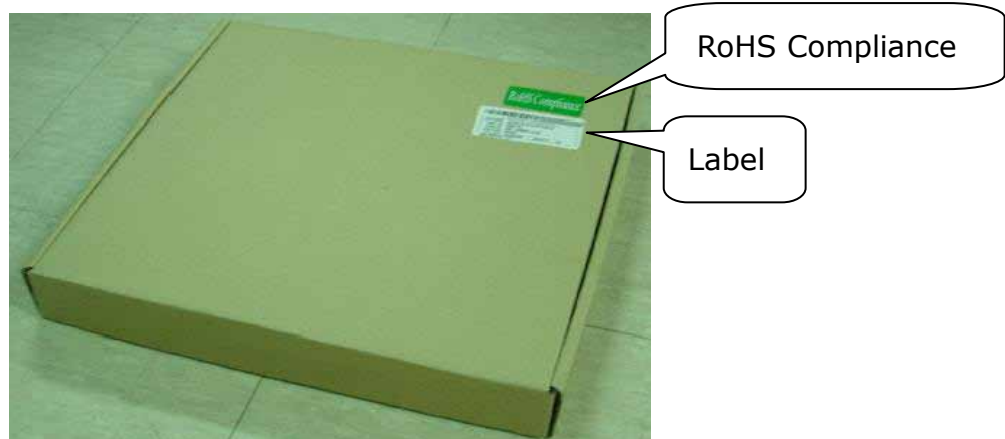

### 5.3.2 Outer Box

Size : 405 (W) x 360 (D) x 300 (T) (mm)

Quantity : 5 Inner Box (1,000 ea/Inner Box × 5 Inner Box=5,000 ea)