

未注公差/General tolerances (mm)												0.1/10	
0	>3	>6	>10	>18	>30	>50	>80	>120	>180	>250	>315		>400
~3	~6	~10	~18	~30	~50	~80	~120	~180	~250	~315	~400	~500	>500
±0.12	±0.18	±0.22	±0.26	±0.31	±0.37	±0.57	±0.80	±0.93	±1.05	±1.15	±1.60	±2.20	±2.50

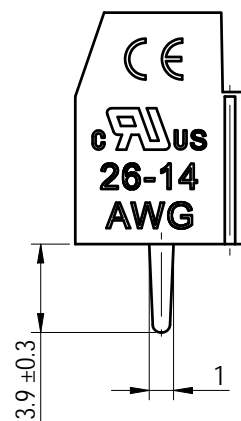

Note:  
The A&Z (H) in the name means: A(H) and Z(H).

ITEM	NAME OF PART	MATERIAL	NOTES
4	pin header	Copper alloy	Sn Plated
3	Spring	Stainless steel	/
2	Screw	Steel	M2.5/Zn Plated
1	Housing	PA66	UL94V-0

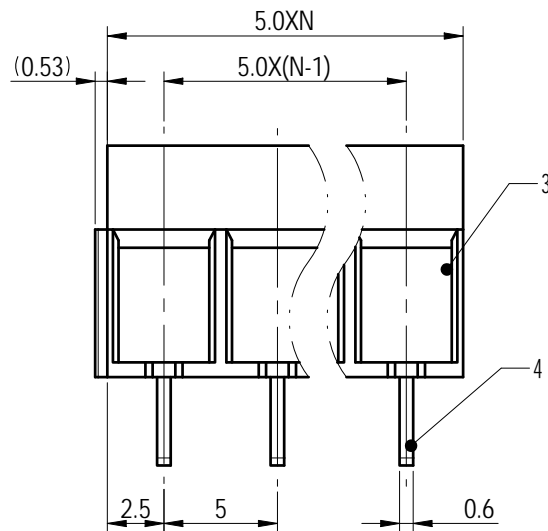
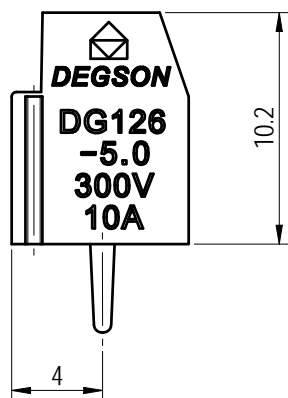
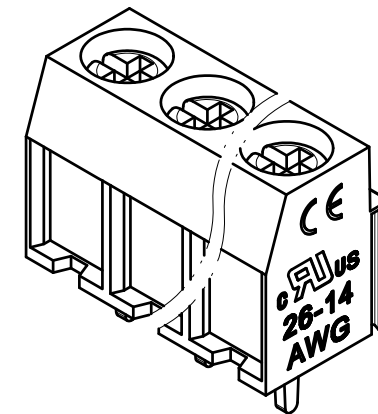
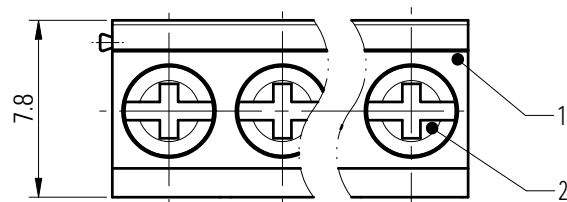
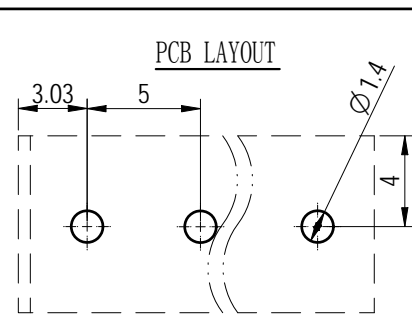

UL 标准/UL Standard:	B	C	D
额定电压/电流/Rated Voltage(V)/Current(A)	300/10	/	/
IEC 标准/IEC Standard:			
过压类别/Overvoltage Category/污染等级/Pollution Degree	III/3	III/2	II/2
额定电压/电流/Rated Voltage(V)/Current(A)	/	250/17.5	/
工频耐压/Withstanding voltage (V/1Min)	AC2000		
螺丝扭矩/Torque Tightening(N·m/Lb.in)	M2.5, 0.3/2.6		
线径范围(硬线和软线)/Wire Range(rigid and flexible)(AWG/mm²)	26~14 / 0.5~1.5		
间距/Pitch(mm)/线数范围/Poles	5.0/N=02~24P		
剥线长度/Stripping length(mm)	6~7		
使用温度范围/Operating temperature(°C)	-40~+105		
符合RoHS环保要求/Conform to RoHS	Yes		

**DEGSON**

APPD: 兰春华 2022.08.05  
CHKD: 陈招 2022.08.04  
DRFT: 龚徐涛 2022.08.03

MATERIAL:	SURFACE/COLOR:		
MAT NO./REV:	/ 00	MAT STATUS: 批量	
NAME	DG126-5.0-XXP-1Y-00A&Z(H)		

00	REV	ECN	DESCRIPTION	DRFT	DATE	200031776	TYPE	DRAWING STATUS	SCALE	SHEET
				龚徐涛	2022.08.03	200031776	CUSTOMER DRAWING	已发布	3:1	1/1

Transfer or duplication of this document as well as the utilization or communication of its content are prohibited unless authorized in writing by DEGSON. All rights reserved for patent. 除专利号外, 其他内容均受法律保护, 未经许可, 不得复制或传播。 凡在本公司网站或产品资料中出现的 DEGSON 标志, 均受法律保护, 未经许可, 不得复制或传播。 凡在本公司网站或产品资料中出现的 DEGSON 标志, 均受法律保护, 未经许可, 不得复制或传播。