

未注公差/General tolerances (mm)													0.1/10
0	>3	>6	>10	>18	>30	>50	>80	>120	>180	>250	>315	>400	
~3	~6	~10	~18	~30	~50	~80	~120	~180	~250	~315	~400	~500	>500
±0.12	±0.18	±0.22	±0.26	±0.31	±0.37	±0.57	±0.80	±0.93	±1.05	±1.15	±1.60	±2.20	±2.50

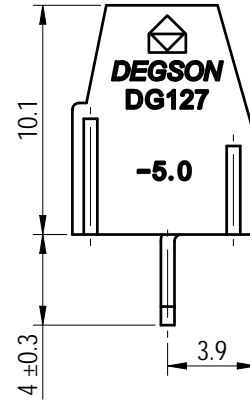
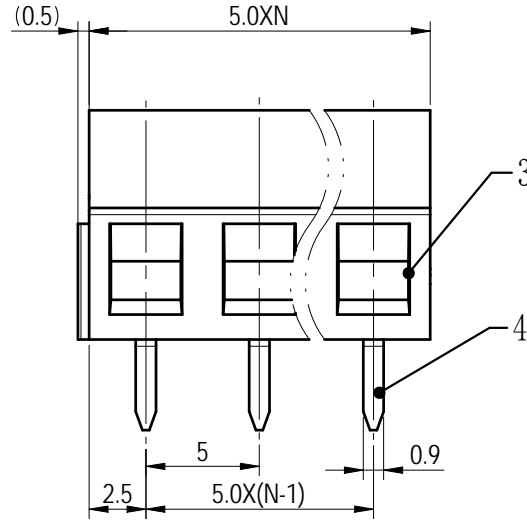
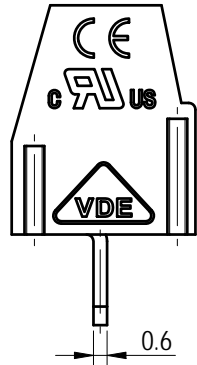
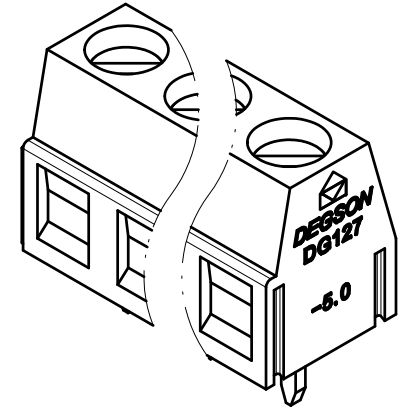
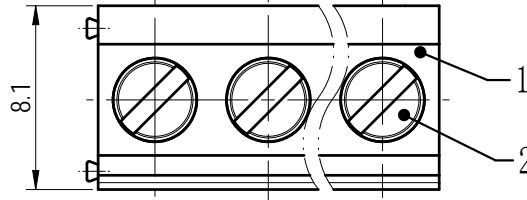

Note:
The A&Z(H) in the name means: A(H) and Z(H).

ITEM	NAME OF PART	MATERIAL	NOTES
4	pin header	Copper alloy	Sn Plated
3	Cage	Copper alloy	M2.5/Ni Plated
2	Screw	Steel	M2.5/Zn Plated
1	Housing	PA66	UL94V-0

UL 标准/UL Standard:	B	C	D
额定电压/电流/Rated Voltage(V)/Current(A)	300/12	/	300/10
IEC 标准/IEC Standard:			
过压类别/Overvoltage Category/污染等级/Pollution Degree	III/3	III/2	II/2
额定电压/电流/Rated Voltage(V)/Current(A)	/	250/15	/
工频耐压/Withstanding voltage (V/1Min)	AC2000		
螺丝扭矩/Torque Tightening(N·m/Lb.in)	M2.5, 0.4/3.5		
线径范围(硬线和软线)/Wire Range(rigid and flexible)(AWG/mm²)	26~14 / 0.75~1.5		
间距/Pitch(mm)/线数范围/Poles	5.0/N=02~24P		
剥线长度/Stripping length(mm)	6~7		
使用温度范围/Operating temperature(°C)	-40~+105		
符合RoHS环保要求/Conform to RoHS	Yes		

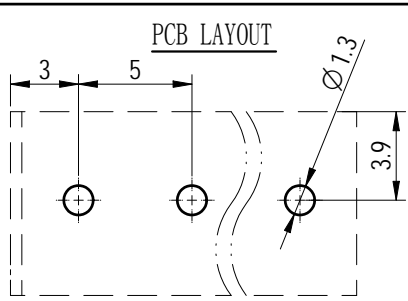

DEGSON

MATERIAL: SURFACE/COLOR:
MAT NO./REV: / 00 MAT STATUS: 批量

APPD: 兰春华 2022.08.05
CHKD: 陈招 2022.08.04
DRFT: 龚徐涛 2022.08.03

DRAWING NO. 200031768 TYPE CUSTOMER DRAWING DRAWING STATUS 已发布 SCALE 3:1 SHEET 1/1

REV	ECN	DESCRIPTION	DRFT	DATE
00			龚徐涛	2022.08.03

Transfer or duplication of this document as well as the utilization or communication of its contents are prohibited unless authorized in writing by DEGSON. All rights reserved for patent, utility model or design registrations. 除专利等明确标注外, 未经许可, 不得复制或传播。 未经授权, 不得复制或传播。 未经授权, 不得复制或传播。