



深圳匡通电子有限公司
SHENZHEN KENTO ELECTRONICCO.,LTD

产 品 规 格 书

Data Sheet

Product Name: LED 3528 Warm white

Product number: KT-3528-PW

Customer Name: _____

Version number: A.2

Date Prepared: 2015-10-23

Customer recognition column		

一、 Product Description :

- Dimensions (L/W/H): 3.5×2.8×1.9 mm
- Color: high brightness white
- EIA standard packaging
- Environmentally friendly products, in line with ROHS requirements
- Suitable for automatic placement machine
- Suitable for infrared reflow soldering process

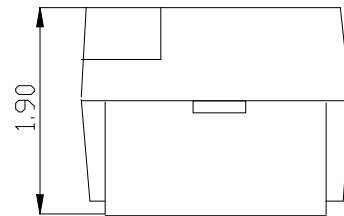
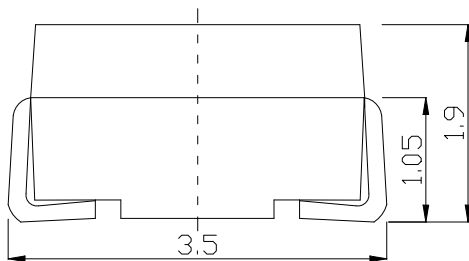
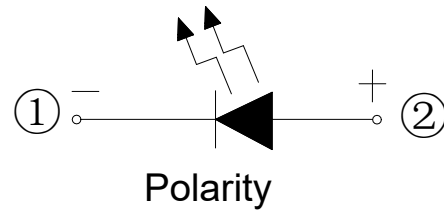
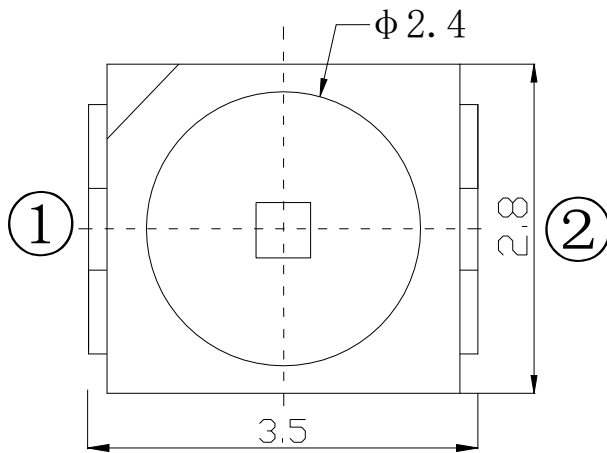
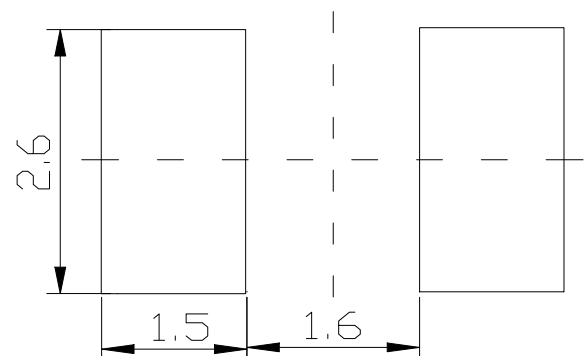
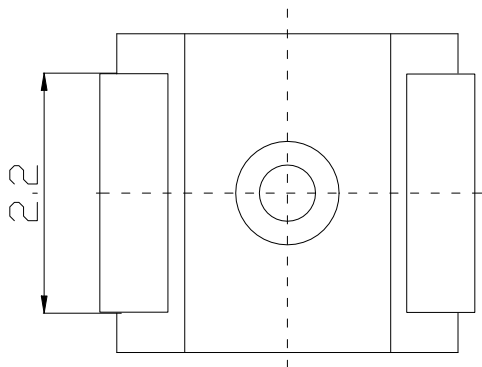
二、 Dimensions and Recommended Pad Size :**Recommended land size:**

Note: 1. Unit: millimeter (mm).

2. Tolerance: ± 0.10 mm if there is no special label.

三. Recommended Welding Temperature Curve :

Lead solder :

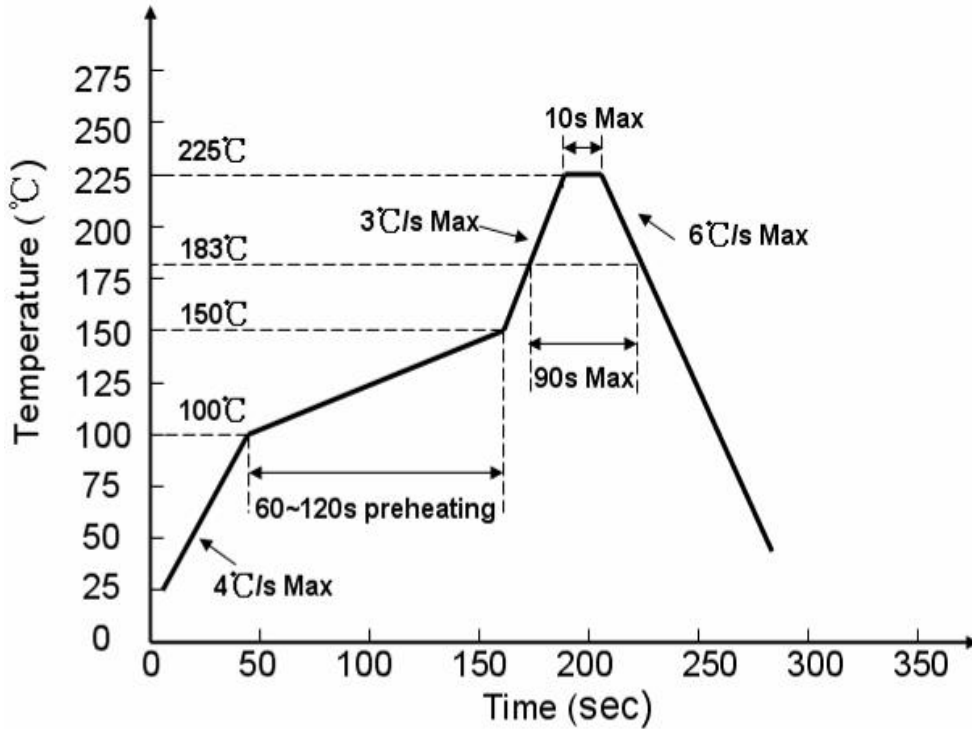

Lead-free soldering :

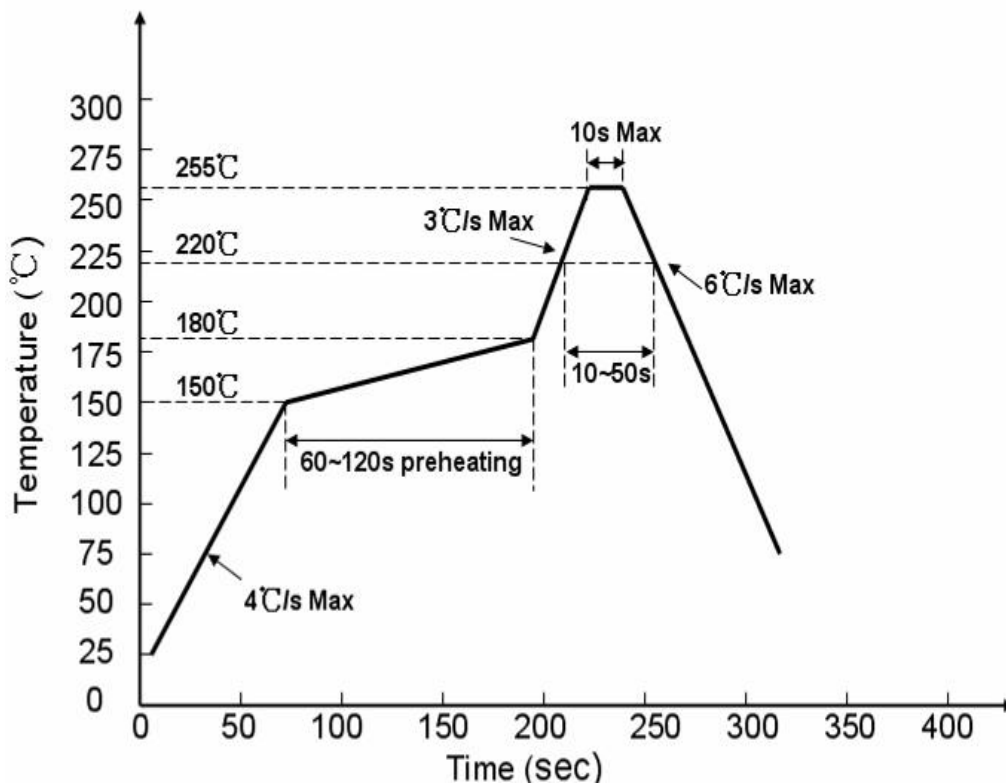



匡通电子

Product Specification Book

Part No. : **KT-3528PW**

Version

A.2

Release date

2015.10.23

Page number

3 of 13

四、 Photoelectric parameters (Ta=25°C):

Parameter	Symbol	Maximum rating	Unit
Power dissipation	Pd	90	mW
Peak pulsing current (1/10 duty cycle, 0.1ms pulse width)	IFP	100	mA
Forward DC working current	IF	20	mA
Reverse voltage	VR	5	V
Operating temperature range	Topr	-30°C ~ +85°C	
Storage temperature range	Tstg	-40°C ~ +90°C	
Welding Conditions	Tsol	Reflow soldering: 260°C, 10s manual soldering: 300°C, 3s	
Antistatic ability	ESD	2000	V

五、 Photoelectric parameters (Ta=25°C):

Parameter	Symbol	Min	Typ	Max	Unit	Test Condition
Light Intensity	IV	---	2000	---	mcd	IF = 20mA
Luminous	Φ	6.1	5	8.7	lm	IF = 20mA
Explicit	Ra		75			IF = 20mA
Half-light angle	2θ1/2	---	120	---	deg	IF = 20mA
Color coordinates	---	---	X:0.29 Y:0.29	--	---	IF=20mA
Color temperature	CCT	7000		11000	K	IF=20mA
Forward Voltage	VF	2.8	---	3.2	V	IF=20mA
Reverse current	IR	---	---	5	uA	VR=5V



匡通电子

Product Specification Book

Part No. : KT-3528PW

Version

A.2

Release date

2015.10.23

Page number

4 of 13

六、 BIN specifications

1、 Brightness sub-BIN specification

Bin	Min	Max	Unit	Condition
T1	2670	3500	MCD	IF=0mA
2	3500	4500		
U1	4500	5600		

2、 Voltage sub-BIN specifications

Bin	Min	Max	Unit	Condition
6	2.8	3.0	V	IF=20mA
7	3.0	3.2		
8	3.2	3.4		
9	3.4	3.6		

1、 Color classification BIN specifications

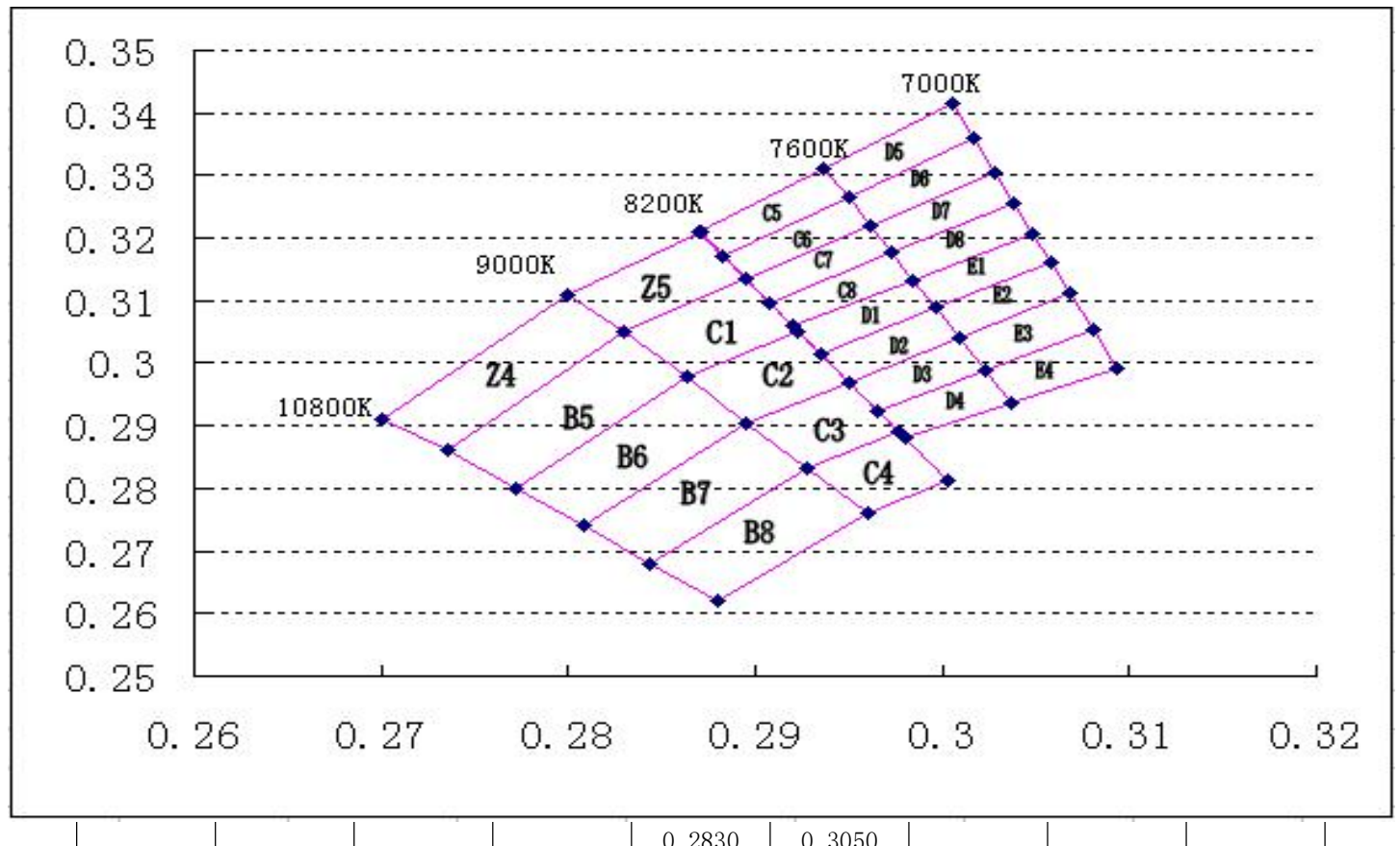

0.2830 0.3050



匡通电子

Product Specification Book

Part No. : **KT-3528PW**

Version

A.2

Release date

2015.10.23

Page number

5 of 13

E2	0.2997	0.3088	C2	0.2863	0.2978	D2	0.2935	0.3015
	0.3009	0.3042		0.2895	0.2905		0.2950	0.2970
	0.3068	0.3113		0.2950	0.2970		0.3009	0.3042
	0.3058	0.3160		0.2923	0.3052		0.2997	0.3088
E3	0.3009	0.3042	C3	0.2895	0.2905	D3	0.2950	0.2970
	0.3023	0.2990		0.2928	0.2833		0.2965	0.2925
	0.3081	0.3053		0.2977	0.2891		0.3023	0.2990
	0.3068	0.3113		0.2950	0.2970		0.3009	0.3042
E4	0.3023	0.2990	C4	0.2928	0.2833	D4	0.2965	0.2925
	0.3037	0.2937		0.2977	0.2891		0.2980	0.2880
	0.3093	0.2993		0.3003	0.2812		0.3037	0.2937
	0.3081	0.3053		0.2960	0.2760		0.3023	0.2990
B5	0.2735	0.2860	C5	0.2883	0.3172	D5	0.2937	0.3312
	0.2772	0.2800		0.2870	0.3210		0.2950	0.3266
	0.2863	0.2978		0.2937	0.3312		0.3017	0.3360
	0.2830	0.3050		0.2950	0.3266		0.3005	0.3415
B6	0.2735	0.2860	C6			D6	0.2937	0.3312
	0.2772	0.2800		0.2883	0.3172		0.2950	0.3266
	0.2808	0.2740		0.2950	0.3266		0.2962	0.3220
	0.2895	0.2905		0.2962	0.3220		0.3028	0.3304
B7	0.2863	0.2978	C7	0.2895	0.3134	D7	0.3017	0.3360
	0.2808	0.2740		0.2883	0.3172		0.2950	0.3266
	0.2895	0.2905		0.2908	0.3097		0.2973	0.3177
	0.2844	0.2680		0.2973	0.3177		0.3038	0.3256
B8	0.2895	0.2905	C8	0.2962	0.3220	D8	0.3028	0.3304
	0.2844	0.2680		0.2908	0.3097		0.2973	0.3177
	0.2928	0.2833		0.2920	0.3060		0.2984	0.3133
	0.2960	0.2760		0.2984	0.3133		0.3048	0.3207
Z4	0.2880	0.2620	Z5	0.2973	0.3177		0.3038	0.3256
	0.27	0.291		0.28	0.311			
	0.28	0.311		0.2871	0.321			
	0.283	0.305		0.2895	0.3134			
				0.283	0.305			

Notes: Tolerance of the CIE X,Y : +/-0.005

七、 Characteristic curve of photoelectric parameter representative value:

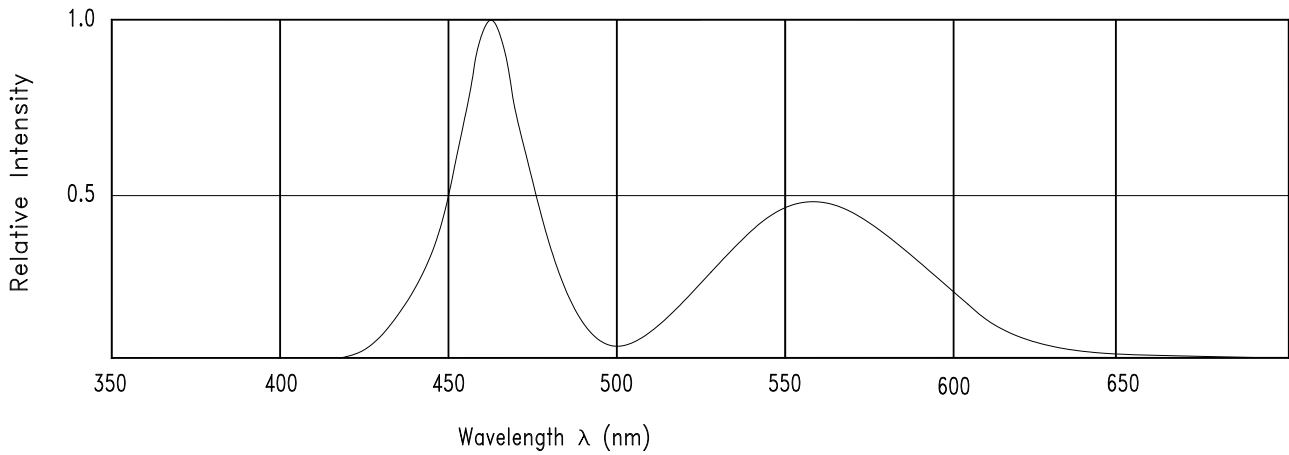

Fig.1 Relative Intensity vs. Wavelength

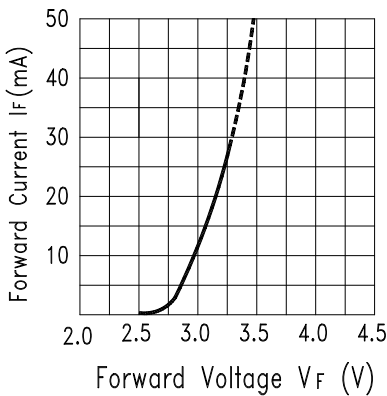

Fig.2 Forward Current vs. Forward Voltage

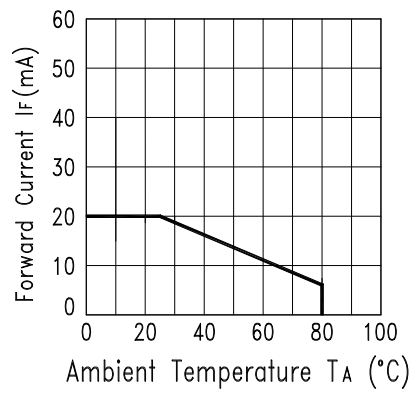

Fig.3 Forward Current Derating Curve

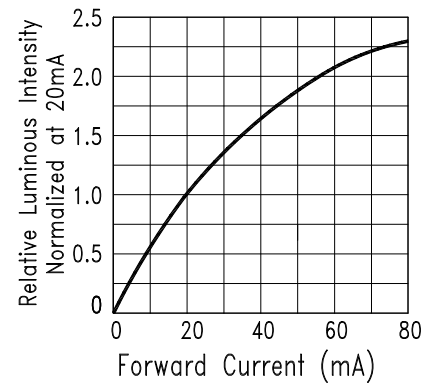

Fig.4 Relative Luminous Intensity vs. Forward Current

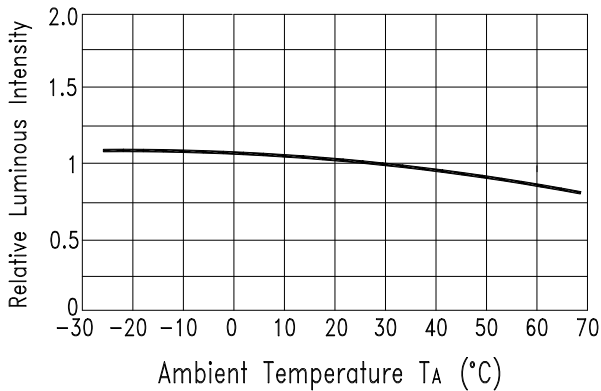

Fig.5 Luminous Intensity vs. Ambient Temperature

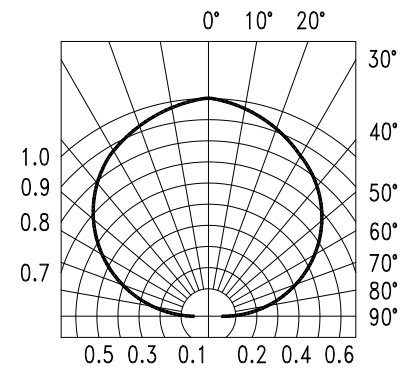

Fig.6 Spatial Distribution

八、 Label identification:

CAT: Light intensity (unit (mcd))

HUE: color coordinate

REF: Voltage (Unit (V))

九、 Packing tape and disc size:

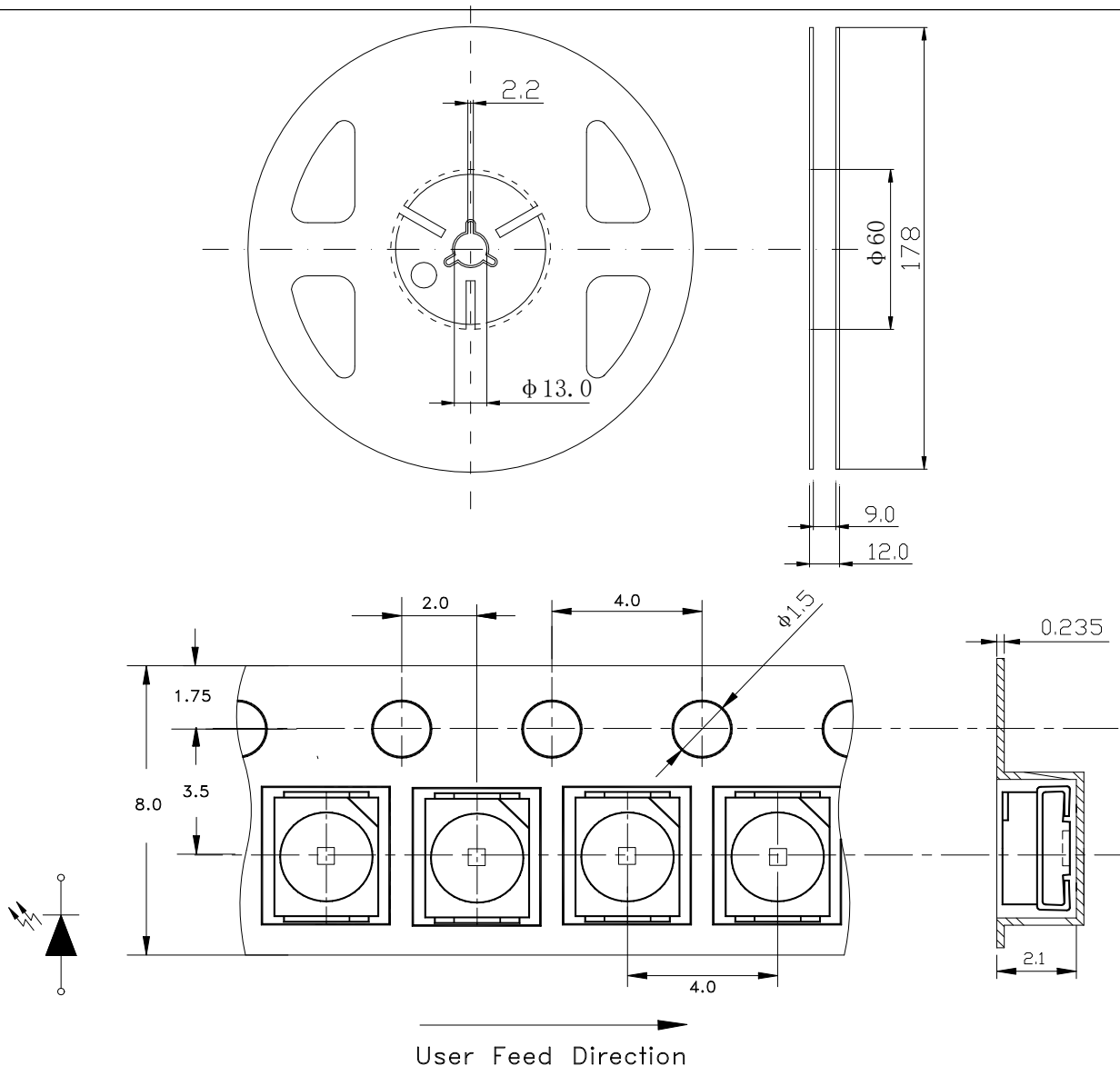

Note: 1. The size unit is millimeter (mm);

2. The size tolerance is ± 0.1 mm;

十、 Disc and carrier tape unwinding direction and cavity specifications:

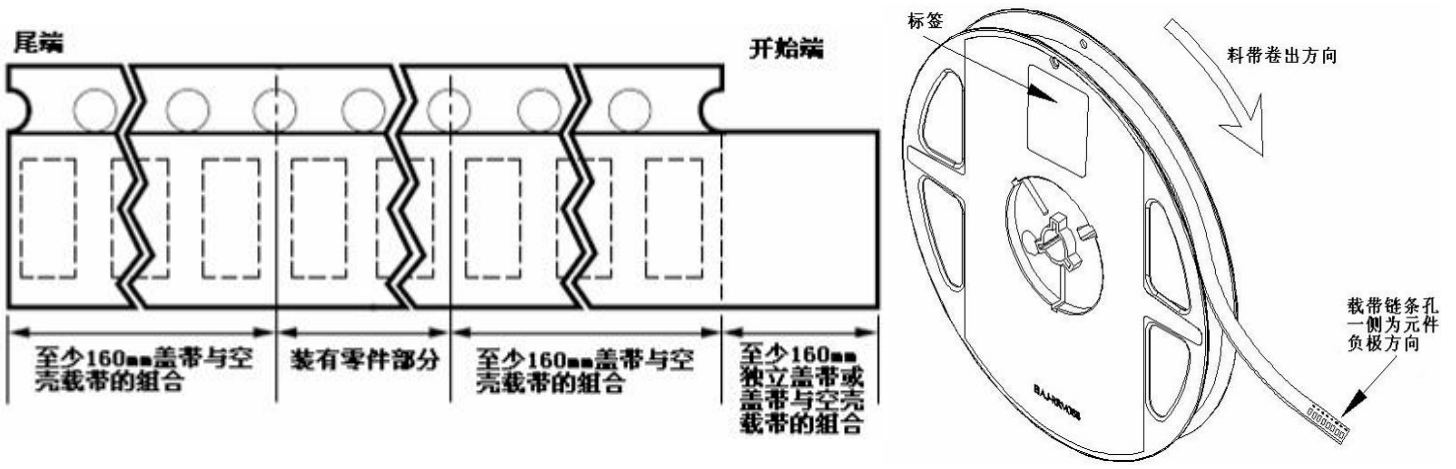

十一、 Inner packaging and outer packaging:

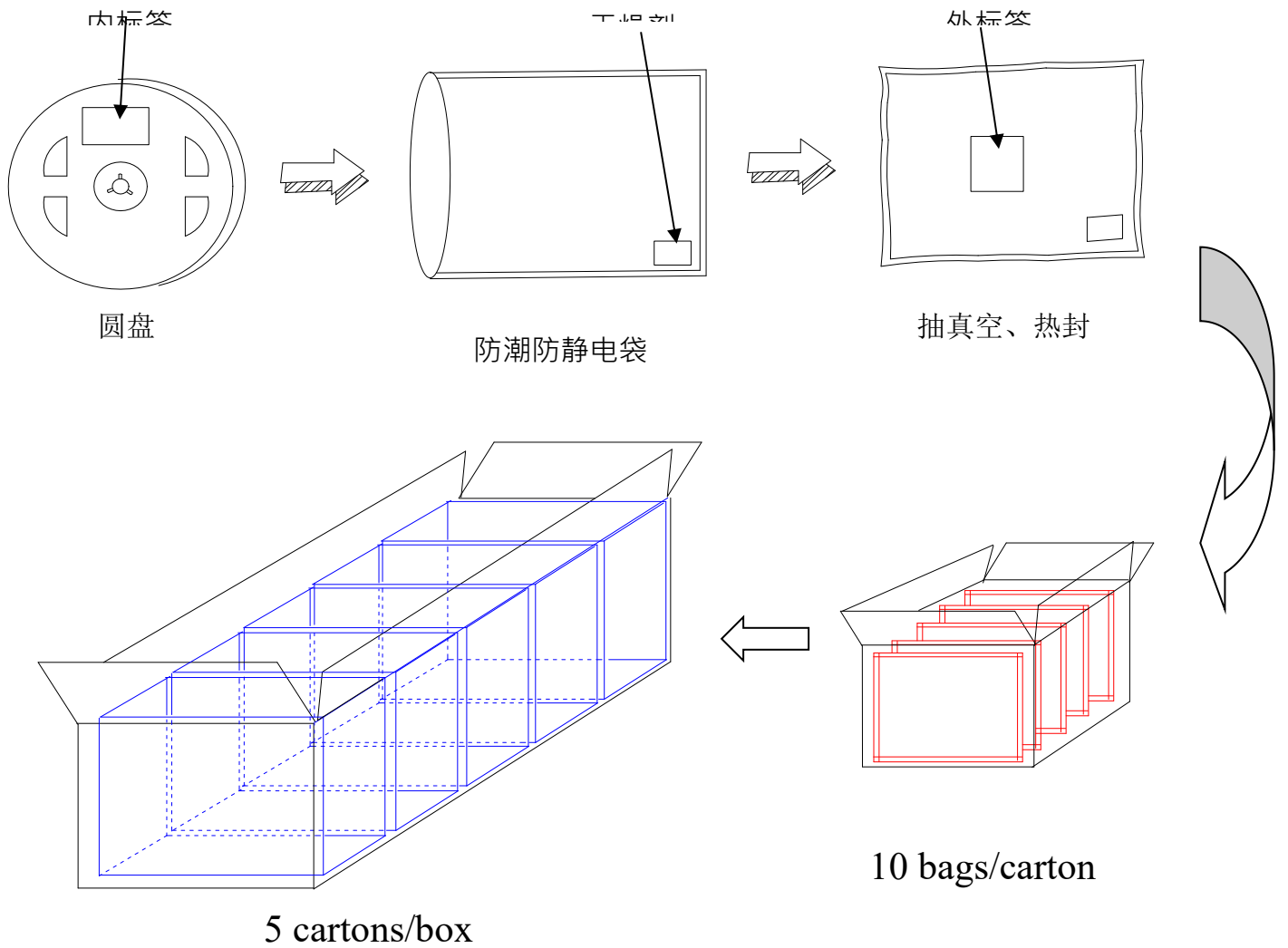



匡通电子

Product Specification Book

Part No. : **KT-3528PW**

Version

A.2

Release date

2015.10.23

Page number

9 of 13

十二、 Reliability test

Poject	TEST ITEM	TEST ENVIRONMENT	TEST TIMES	Failure LED sums (PCS)
Durability test	Life span	Continuous lighting with maximum rated current at room temperature; Test at 20mA.	1000 hours (- 24 hours, + 72 hours)	MIL-STD-750D:1026 MIL-STD-883D:1005 JIS C 7021:B-1
	High temperature and humidity storage	IR-Reflow In-Board, 2 Times Ambient temperature Ta= 65±5°C, relative humidity RH= 90~95%	240 hours (+ 2 hours)	JESD22-A101
	Hig temperature storage	Ambient temperature Ta= 105±5°C	1000 hours (-24 hours, +72 hours)	MIL-STD-883D:1008 JIS C 7021:B-10
	Low temperature storage	Ambient temperature Ta= -55±5°C	1000 hours (-24 hours, +72 hours)	JIS C 7021:B-12
Environmental testing	Tperature cycle	105°C ~ 25°C ~ -55°C ~ 25°C 30mins 5mins 30mins 5mins	10 cycles	MIL-STD-202F:107D MIL-STD-750D:1051 MIL-STD-883D:1010 JIS C 7021:A-4
	Thermal Shock	IR-Reflow In-Board, 2 Times 85 ± 5°C ~ -40°C ± 5°C 10mins 10mins	10 cycles	MIL-STD-202F:107D MIL-STD-750D:1051 MIL-STD-883D:1011
	Tin resistance test	Solder temperature T.sol= 260 ± 5°C	10 ± 1secs 2times	MIL-STD-202F:210A MIL-STD-750D:2031 JIS C 7021:A-1
	Infrared reflow soldering Lead process	Heating rate (183°C to the highest value): maximum 3°C/sec Maintain the temperature at 125(±25)°C: no more than 120 seconds Maintain the temperature above 183°C: 60-150 seconds Maximum temperature limit range: 235°C+5/-0°C Maintain at 235°C+5/-0°C Time: 10-30 seconds Cooling speed: Max 6°C/sec	-----	MIL-STD-750D:2031.2 J-STD-020C

	Low temperature storage	Heating rate (217°C to the highest value): maximum 3°C/sec Maintain the temperature at 175(±25)°C: no more than 180 seconds Maintain the temperature above 217°C: 60-150 seconds Maximum temperature limit range: 260°C+0/-5°C Maintain at 260°C+0/-5°C Time: 20-40 seconds Cooling speed: Max 6°C/sec	-----	MIL-STD-750D:2031.2 J-STD-020C
	Temperature cycle	Soldering temperature T.sol = 235 ± 5°C Immersion speed: 25±2.5 mm/sec Soldering rate ≧95% pad area	Immersion time: 2±0.5 秒	MIL-STD-202F:208D MIL-STD-750D:2026 MIL-STD-883D:2003 IEC 68 Part 2-20 JIS C 7021:A-2

十三、 Attention:

During using:

- LED is a current driving element, and the slight change of voltage will produce a large current fluctuation, which will cause the element to be damaged. The customer should use resistance series connection as current limiting protection
- In order to ensure the light color consistency of multiple LEDs in parallel, it is recommended to use a separate resistor for each branch, as shown in mode a below; As shown in mode B below, LED light color may differ due to different volt ampere characteristics of each LED

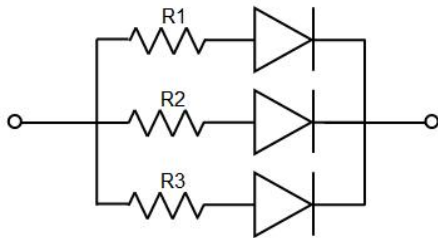

电路模式 A

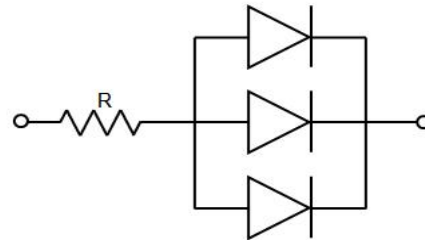

电路模式 B

3. Too high ambient temperature will affect the brightness and other performance of LED, so in order to make LED have better performance, it should be far away from the heat source.

4. Photoelectric parameter tolerance:

Forward voltage REF / VF : ± 0.02V

Brightness CAT / IV : ± 11%

Wavelength HUE / WLD : ± 1nm



国通电子

Product Specification Book

Part No. : **KT-3528PW**

Version

A.2

Release date

2015.10.23

Page number

11 of 13

Storage:

1. Without opening the original packaging, the recommended storage environment is: Temperature: 5°C~30°C; Humidity: 85%RH or less. When the stock is more than 2 months, it should be dehumidified before use. The condition is 60°C/ 8 hours.
2. After opening the original packaging, the recommended storage environment is: temperature 5~30°C; humidity below 60%.
3. LED is a humidity sensitive element. To avoid moisture absorption, it is recommended to store it in a closed container with desiccant or in a nitrogen moisture-proof cabinet after opening the package.
4. After opening the package, the components should be used within 48 hours (2 days); and soldering should be done as soon as possible after mounting.
5. If the desiccant fails or the component is exposed to the air for more than 48 hours (2 days), it should be dehumidified.

Baking conditions: 60°C, 24 hours.

ESD electrostatic protection

LEDs (especially blue, emerald, purple, white, and pink LEDs with InGaN structure) are electrostatic sensitive components, and static electricity or current overload will destroy the LED structure. LED damage by static electricity or current overload may cause abnormal performance, such as excessive leakage current, low VF, or failure to light up, etc. So please note the following:

1. Wear an anti-static wrist strap or anti-static gloves when touching LEDs.
2. All machinery and equipment, tools, work tables, material racks, etc., should be properly grounded (the grounding impedance value is within 10Ω).
3. Use anti-static bags, anti-static boxes, and anti-static turnover boxes to store or transport LEDs. It is strictly forbidden to use ordinary plastic products.
4. It is recommended to use ion fans to suppress the generation of static electricity during operation.
5. The electrostatic field voltage is less than 100V within an environmental range of 1 foot away from the LED element.

Cleaning

It is recommended to use alcohol solutions such as isopropanol to clean the LED, and it is strictly prohibited to use corrosive solutions.

Welding

1. For reflow soldering conditions, refer to the temperature curve on the first page.
2. The number of reflow soldering should not exceed twice.
3. It is only recommended to use manual welding in the case of repair and heavy work; the maximum welding temperature should not exceed 300 degrees and must be completed within 3 seconds. The maximum power of the soldering iron should not exceed 30W.
4. During the welding process, it is strictly forbidden to touch the colloid at high temperature.
5. After soldering, it is forbidden to apply external force to the colloid, and it is forbidden to bend the PCB to avoid impact on the components.



匡通电子

Product Specification Book

Part No. : **KT-3528PW**

Version

A.2

Release date

2015.10.23

Page number

12 of 13

Other

1. The LED definition described in this specification is applied to the range of ordinary electronic equipment (such as office equipment, communication equipment, etc.). If there are more stringent reliability requirements, especially when component failure or failure may directly endanger life and health (such as aerospace, transportation, transportation, medical equipment, safety protection, etc.), please inform us in advance Division business staff.

2. High-brightness LED products may cause damage to human eyes when lit, so avoid looking directly from above.

3. For the purpose of continuous improvement, product appearance and parameter specifications may be subject to improved changes without prior notice.

4. Please avoid using materials containing sulfur to avoid affecting the plating surface.

5. Corrosive gases will deteriorate the surface of the LED plating and affect the weldability and optical properties. For example: sulfur.