

Step Angle	0.9°
Step Angle Accuracy	±5% (full step, no load)
Resistance Accuracy	±10%
Inductance Accuracy	±20%
Temperature Rise	80 °C Max.(rated current, 2 phase on)
Ambient Temperature	-20 °C ~ +50 °C
Insulation Resistance	100 MΩ Min., 500VDC
Dielectric Strength	500 VAC for one minute
Shaft Radial Play	0.02 Max. (450 g-load)
Shaft Axial Play	0.08 Max. (450 g-load)

Specifications

Model	Current	Resistance	Inductance	Holding Torque	Detent Torque	Rotor Inertia	Bi/Unipolar	Weight	Length
	A/∅	Ω/∅	mH/∅	N.cm	N.cm	g.cm ²	# of Leads	g	mm
PHB57M56-404	4.2	0.4	1.5	100	3.5	280	Bi (4)	680	56

Mechanical Dimension

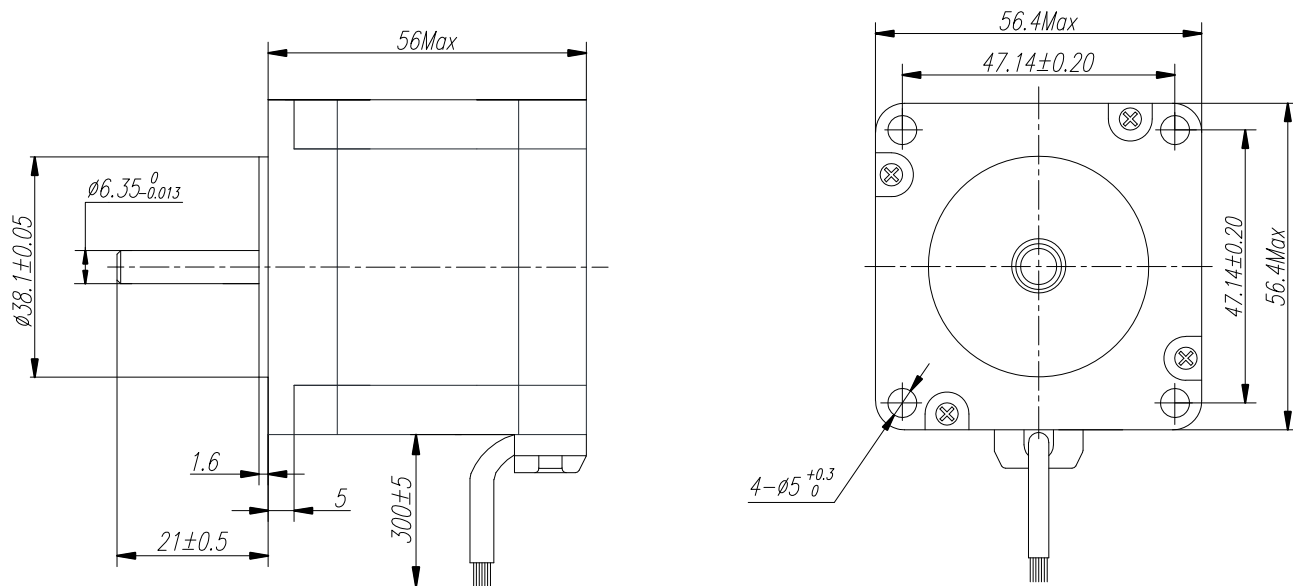

Wiring Diagram

4 Leads

