

REV.	ECN NO.	DATE
01	ADD P/N	08.07.29

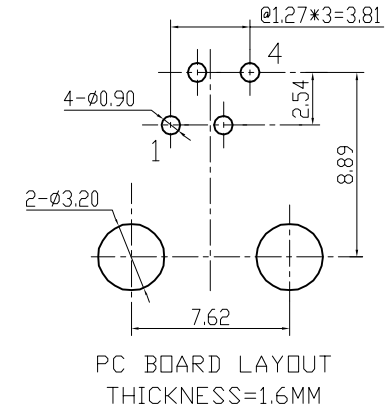
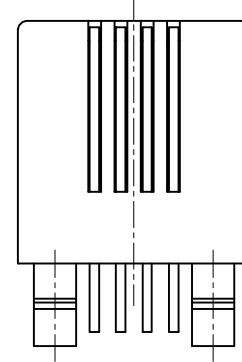
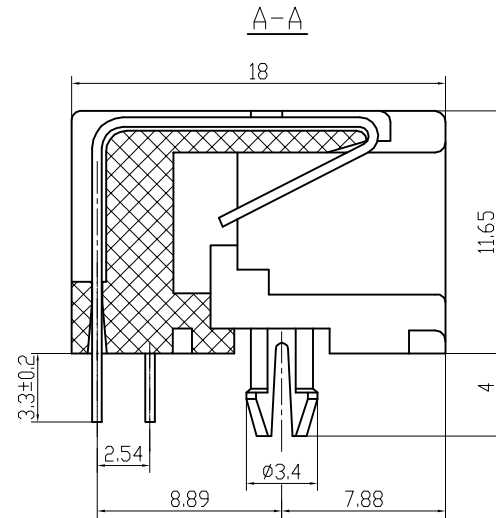
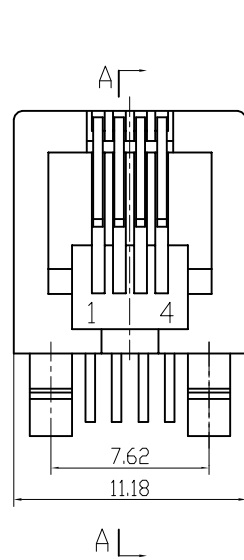

**NOTES:**

**ELECTRICAL:**

- 1. VOLTAGE RATING : 125 VAC RMS.
- 2. CURRENT RATING : 1.5 AMP.
- 3. CONTACT RESISTANCE : 35 MILLIOHMS MAX.
- 4. INSULATION RESISTANCE : 1000 MEGOHMS MIN @ 500 VDC.
- 5. DIELECTRIC STRENGTH : 1000 VAC RMS 60Hz, 1MIN.

**MECHANICAL:**

- 1. HOUSING MATERIAL : PBT UL94V-0.
- 2. CONTACT MATERIAL : PHOSPHOR BRONZE Ø0.46mm.
- 3. PLATING : GOLD PLATING OVER NICKEL.
- 4. OPERATING LIFE : 750 CYCLES MIN.

**ENVIRONMENTAL:**

- 1. STORAGE : -40°C TO +85°C.
- 2. OPERATION : 0°C TO +70°C.

MATES WITH MODULAR PLUG CONFORMING TO  
FCC PART 68, SUBPART F.  
ROHS PART NUMBER:

P/N	DESCRIPTION	CONTACT PLATING GOLD	LOGO	MATERIAL COLOR
B531N-4403-M002	RJ22 1X1 5321 4P4C WITH SPLIT PEG JACK	3u"	NO LOGO	BLACK

RoHS Compliant

<b>意华通讯接插件有限公司</b> YIHUA COMMUNICATED CONNECTOR CO.,LTD.		TOLERANCES .0 ± 0.25 .00 ± 0.20 .000 ± 0.10 ANGLES ± 0.5	MATERIAL: SEE_NOTE FINISH: SEE_NOTE SHEET 1 OF 1	DESIGNED: Chen zhiyan 08/07/28 CHECKED: APPROVED:	NAME: RJ22 1X1 5321 4P WITH SPLIT PEG JACK DWG NO: E53QWY-1056-25 PART NO: SEE_NOTE	REV 01
FIRST ANGLE PROJECTION	A4 SIZE	SCALE: 1:1 UNIT: mm	CUSTOMER: N/A MODEL NO: N/A			