

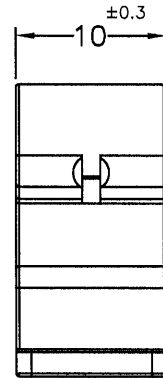

REVISIONS			
REV	DESCRIPTION	DATE	BY

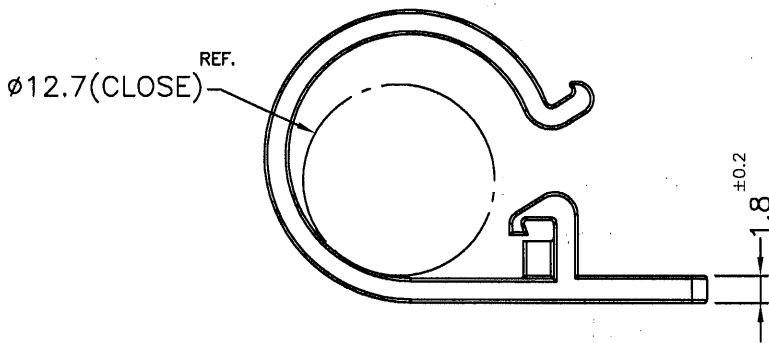
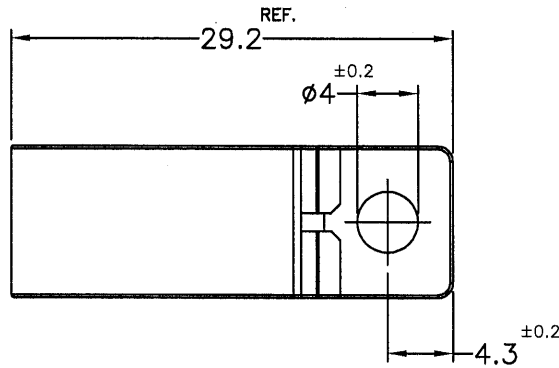

PART NO.	MATERIAL	COLOR
CCB-1B	NYLON 66 UL94V-2	BLACK
CCB-1		NATURAL
CCB-1V0	NYLON 66 UL94V-0	NATURAL(WHITE)

NOTE: 1. SHRINKING IS NORMAL STATUS.
 內縮為正常現象。
 2. MADE OF EQUIVALENT MATERIAL.
 均可使用同等材質。



 康揚企業股份有限公司 KANG YANG HARDWARE ENTERPRISE CO., LTD. 康揚塑膠(東莞)有限公司 KANG YANG PLASTIC(DONG GUAN)CO.,LTD. 康哲電腦配件(吳江)有限公司 KANG CHE COMPUTER COMPONENTS(WUJIANG) CO.,LTD.				TITLE	WIRE MOUNT	SPEC. DWG.	
				MATERIAL	SEE ABOVE	DATE	2010.01.04
				FINISH		DRAWN	T.C
PART NUMBER		DRAWING NUMBER		COLOR	CHECK		
SEE ABOVE		CCB-1		SEE ABOVE		薛梅	
SIZE	SCALE	UNIT	REV	UNLESS OTHERWISE SPECIFIED TOLERANCE	APPROVED		
A4	2:1	mm	A	SEE ABOVE	Kang		