

Dual-Channel Delta-Sigma Analog-to-Digital Converter

Features

- Synchronous Sampling
- On-chip 1.2 V Reference (25 ppm/°C typ.)
- Power Supply Configurations:
 - VA+ = +3 V; VA- = -2 V; VD+ = +3 V
 - Supply tolerances ±10%
- Power Consumption
 - 10 mW Typical at VD+ = +3 V
- Simple Four-wire Serial Interface
 - High-Speed DMA Capability
- Charge Pump Driver output generates negative power supply.
- Ground-Referenced Bipolar Inputs

Description

The CS5471 is a highly integrated Delta-Sigma ($\Delta\Sigma$) Analog-to-Digital Converter (ADC) developed for the Power Measurement Industry. The CS5471 combines two $\Delta\Sigma$ ADCs, decimation filters, and a serial interface on a single chip. The CS5471 interfaces directly to a current transformer or shunt to measure current, and resistive divider or transformer to measure voltage. The product features a serial interface for communication with a micro-controller or DSP. The product is initialized and fully functional upon reset, and includes a Voltage Reference.

ORDERING INFORMATION:

CS5471-BS -40°C to +85°C 20-pin SSOP

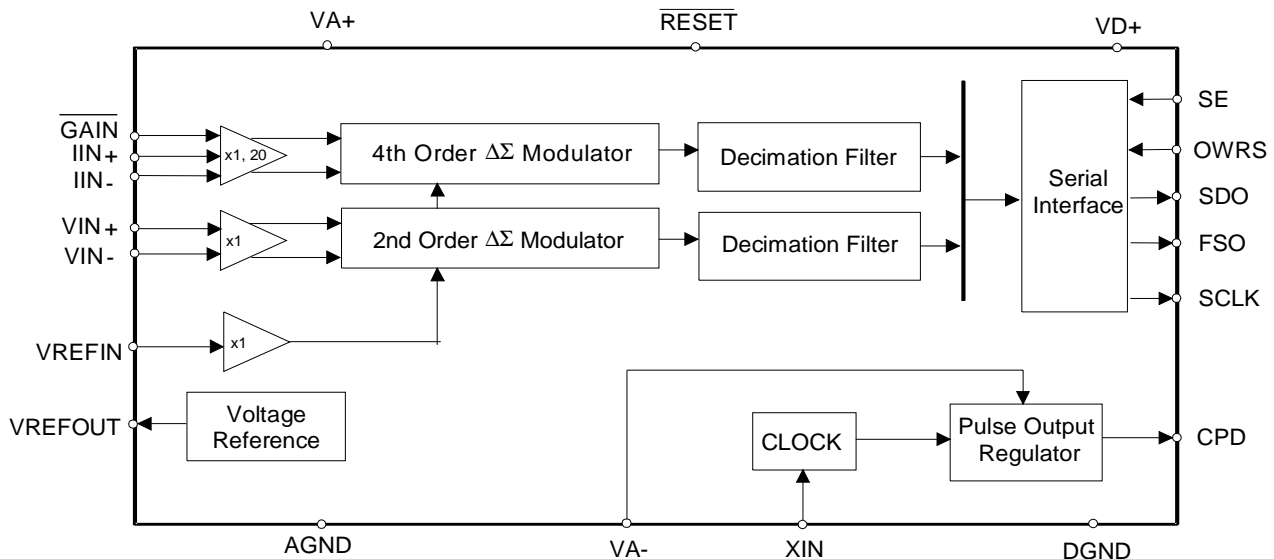

TABLE OF CONTENTS

1. CHARACTERISTICS AND SPECIFICATIONS	3
ANALOG CHARACTERISTICS	3
DIGITAL CHARACTERISTICS	4
RECOMMENDED OPERATING CONDITIONS	4
ABSOLUTE MAXIMUM RATINGS	5
SWITCHING CHARACTERISTICS	6
2. GENERAL DESCRIPTION	7
2.1 Theory of Operation	7
2.2 Performing Measurements.....	7
2.3 High Rate Digital Filters	8
2.4 Serial Interface.....	8
2.5 System Initialization	9
2.6 Analog Inputs.....	9
2.7 Voltage Reference	9
2.8 Power Supply.....	9
3. PIN DESCRIPTION	10
4. PACKAGE DIMENSIONS.....	12

LIST OF FIGURES

Figure 1. Serial Port Timing.....	6
Figure 2. Typical Connection Diagram	7
Figure 3. Serial Port Data Transfer	8
Figure 4. Closeup of One Frame.....	8
Figure 5. Generating VA- with a Charge Pump.....	9

Contacting Cirrus Logic Support

For a complete listing of Direct Sales, Distributor, and Sales Representative contacts, visit the Cirrus Logic web site at:
<http://www.cirrus.com/corporate/contacts/sales/cfm>

Preliminary product information describes products which are in production, but for which full characterization data is not yet available. Advance product information describes products which are in development and subject to development changes. Cirrus Logic, Inc. has made best efforts to ensure that the information contained in this document is accurate and reliable. However, the information is subject to change without notice and is provided "AS IS" without warranty of any kind (express or implied). No responsibility is assumed by Cirrus Logic, Inc. for the use of this information, nor for infringements of patents or other rights of third parties. This document is the property of Cirrus Logic, Inc. and implies no license under patents, copyrights, trademarks, or trade secrets. No part of this publication may be copied, reproduced, stored in a retrieval system, or transmitted, in any form or by any means (electronic, mechanical, photographic, or otherwise) without the prior written consent of Cirrus Logic, Inc. Items from any Cirrus Logic website or disk may be printed for use by the user. However, no part of the printout or electronic files may be copied, reproduced, stored in a retrieval system, or transmitted, in any form or by any means (electronic, mechanical, photographic, or otherwise) without the prior written consent of Cirrus Logic, Inc. Furthermore, no part of this publication may be used as a basis for manufacture or sale of any items without the prior written consent of Cirrus Logic, Inc. The names of products of Cirrus Logic, Inc. or other vendors and suppliers appearing in this document may be trademarks or service marks of their respective owners which may be registered in some jurisdictions. A list of Cirrus Logic, Inc. trademarks and service marks can be found at <http://www.cirrus.com>.

1. CHARACTERISTICS AND SPECIFICATIONS

ANALOG CHARACTERISTICS ($T_A = -40\text{ }^\circ\text{C}$ to $+85\text{ }^\circ\text{C}$; $+2.7\text{V} < VA+ < +3.5\text{V}$; $+2.7\text{V} < VD+ < +3.5\text{V}$; $VA- = -2\text{V} \pm 10\%$; External $VREF+ = 1.2\text{V}$; $XIN = 4.000\text{MHz}$; $AGND, DGND = 0.0\text{V}$.) (See Notes 1 and 2)

Parameter		Symbol	Min	Typ	Max	Unit
Accuracy (All Channels)						
Total Harmonic Distortion		THD	74	-	-	dB
Common Mode Rejection	(DC, 50, 60 Hz)	CMRR	80	-	-	dB
Common Mode + Signal on Input			VA-	-	VA+	V
Input Sampling Rate			-	XIN/4	-	Hz
Analog Inputs (Current Channel)						
Differential Input Voltage Range	Gain=20	IIN	-40	-	+40	mV
	Gain=1		-800	-	+800	mV
Bipolar Offset	Gain=20	VOS	-	0.500	1	mV
	Gain=1	VOS	-	10	20	mV
Crosstalk with Voltage Channel	(50, 60 Hz)		-	-	-120	dB
Input Capacitance	Gain=20	IC	-	-	20	pF
	Gain=1	IC	-	-	1	pF
Effective Input Impedance	(Note 3)					
	Gain=20	EII	50	-	-	k Ω
	Gain=1	EII	-	500	600	k Ω
Noise (Referred to Input)	0-60 Hz	Gain=20	-	-	1	μV_{rms}
		Gain=1	-	-	20	μV_{rms}
	0-1 kHz	Gain=20	-	-	2.5	μV_{rms}
		Gain=1	-	-	50	μV_{rms}
	0-2 kHz	Gain=20	-	-	3.75	μV_{rms}
		Gain=1	-	-	75	μV_{rms}
Analog Inputs (Voltage Channel)						
Differential Input Voltage Range		IIN	-800		+800	mV
Bipolar Offset	Gain=1	VOS	-	20	25	mV
Crosstalk with Current Channel	(50, 60 Hz)		-	-	-120	dB
Input Capacitance		IC	-	-	0.2	pF
Effective Input Impedance	(Note 3)	EII	-	3	4	M Ω
Noise (Referred to Input)	0-60 Hz		-	-	20	μV_{rms}
	0-1 kHz		-	-	50	μV_{rms}
	0-2 kHz		-	-	75	μV_{rms}
Dynamic Characteristics						
High Rate Filter Output Word Rate	OWRS = "0"	OWR	-	XIN/2048	-	Hz
	OWRS = "1"	OWR	-	XIN/1024	-	Hz

- Notes:
- Specifications guaranteed by design, characterization, and/or test.
 - Analog signals are relative to AGND and digital signals to DGND unless otherwise noted.
 - Effective Input Impedance (EII) varies with clock frequency (XIN) and Input Capacitance (IC)
 $EII = 1/(IC \cdot XIN/4)$

ANALOG CHARACTERISTICS (Continued)

Parameter	Symbol	Min	Typ	Max	Unit	
Reference Output						
Output Voltage	REFOUT	1.15	-	1.25	V	
Temperature Coefficient		-	20	50	ppm/°C	
Load Regulation (Output Current 1µA Source or Sink)	ΔV_R	-	6	10	mV	
Power Supply Rejection	PSRR	60	-	-	dB	
Reference Input						
Input Voltage Range	VREF+	1.15	1.2	1.25	V	
Input Capacitance		-	-	10	pF	
Input CVF Current		-	-	1	µA	
Power Supplies						
Power Supply Currents	I_{A+}	PSCA	-	-	1.5	mA
	I_{D+}	PSCD	-	-	2.5	mA
Power Consumption (Note 4)	PC	-	-	15	mW	
Power Supply Rejection (50, 60 Hz)	PSRR	60	-	-	dB	

Notes: 4. All outputs unloaded. All inputs CMOS level.

DIGITAL CHARACTERISTICS ($T_A = -40\text{ °C to }+85\text{ °C}$; $+2.7\text{ V} < V_{A+} < +3.5\text{ V}$; $+2.7\text{ V} < V_{D+} < +3.5\text{ V}$; $V_{A-} = -2\text{ V} \pm 10\%$; AGND, DGND = 0.0 V) (See Notes 5)

Parameter	Symbol	Min	Typ	Max	Unit
High-Level Input Voltage	V_{IH}	0.6 VD+	-	VD+	V
Low-Level Input Voltage	V_{IL}	0.0	-	0.8	V
High-Level Output Voltage $I_{out} = -5.0\text{ mA}$	V_{OH}	(VD+) - 1.0	-	-	V
Low-Level Output Voltage $I_{out} = 5.0\text{ mA}$	V_{OL}	-	-	0.4	V
Input Leakage Current	I_{in}	-	±1	±10	µA
3-State Leakage Current	I_{OZ}	-	-	±10	µA
Digital Output Pin Capacitance	C_{out}	-	9	-	pF

Notes: 5. All measurements performed under static conditions.

RECOMMENDED OPERATING CONDITIONS (AGND, DGND = 0.0 V)

Parameter	Symbol	Min	Typ	Max	Unit	
DC Power Supplies	Positive Digital	VD+	2.7	3.0	3.5	V
	Positive Analog	VA+	2.7	3.0	3.5	V
	Negative Analog	VA-	-2.2	-2.0	-1.8	V
Voltage Reference Input	VREF+	-	1.2	-	V	

ABSOLUTE MAXIMUM RATINGS (AGND, DGND = 0.0 V; See Note 6.)

Parameter	Symbol	Min	Typ	Max	Unit	
DC Power Supplies	Positive Digital	VD+	-0.3	-	+3.5	V
	Positive Analog	VA+	-0.3	-	+3.5	V
	Negative Analog	VA-	-2.5	-	-0.3	V
Input Current, Any Pin Except Supplies	(Note 7 and 8)	I _{IN}	-	-	±10	mA
Output Current	I _{OUT}	-	-	±25	mA	
Power Dissipation	(Note 9)	PDN	-	-	500	mW
Analog Input Voltage	All Analog Pins	V _{INA}	VA- - 0.3	-	(VA+) + 0.3	V
Digital Input Voltage	All Digital Pins	V _{IND}	-0.3	-	(VD+) + 0.3	V
Ambient Operating Temperature	T _A	-40	-	85	°C	
Storage Temperature	T _{stg}	-65	-	150	°C	

Notes: 6. All voltages with respect to AGND.

7. Applies to all pins including continuous over-voltage conditions at the analog input (AIN) pins.

8. Transient current of up to 100 mA will not cause SCR latch-up. Maximum input current for a power supply pin is ±50 mA.

9. Total power dissipation, including all input currents and output currents.

WARNING: Operation at or beyond these limits may result in permanent damage to the device.

Normal operation is not guaranteed at these extremes.

SWITCHING CHARACTERISTICS ($T_A = -40\text{ }^\circ\text{C}$ to $+85\text{ }^\circ\text{C}$; $V_{A+}, V_{D+} = 3.0\text{ V} \pm 10\%$; $V_{A-} = -2\text{ V} \pm 10\%$; $DGND = AGND = 0.0\text{ V}$; Logic Levels: Logic 0 = 0.0 V, Logic 1 = V_{D+} ; $CL = 50\text{ pF}$)

Parameter	Symbol	Min	Typ	Max	Unit	
Master Clock Frequency (Note 10)	XIN	3	4.000	5	MHz	
Master Clock Duty Cycle	-	40	-	60	%	
Rise Times	Any Digital Input (Note 11)	t_{rise}	-	1.0	μs	
	Any Digital Output	-	50	-	ns	
Fall Times	Any Digital Input (Note 11)	t_{fall}	-	1.0	μs	
	Any Digital Output	-	50	-	ns	
Serial Port Timing						
Serial Clock Frequency (Note 10)	OWRS = "0"	SCLK	-	500	-	kHz
	OWRS = "1"	SCLK	-	1000	-	kHz
Serial Clock	Pulse Width High (Note 10)	t_1	-	0.5	-	SCLK
	Pulse Width Low (Note 10)	t_2	-	0.5	-	SCLK
SCLK falling to New Data Bit	t_3	-	-	50	ns	
FSO Falling to SCLK Rising Delay (Note 10)	t_4	-	0.5	-	SCLK	
FSO Pulse Width (Note 10)	t_5	-	1	-	SCLK	
SE Rising to Output Enabled	t_6	-	-	50	ns	
SE Falling to Output in Tri-state	t_7	-	-	50	ns	

Notes: 10. Device parameters are specified with a 4.000 MHz clock, OWRS = 1.

11. Specified using 10% and 90% points on wave-form of interest. Output loaded with 50 pF.

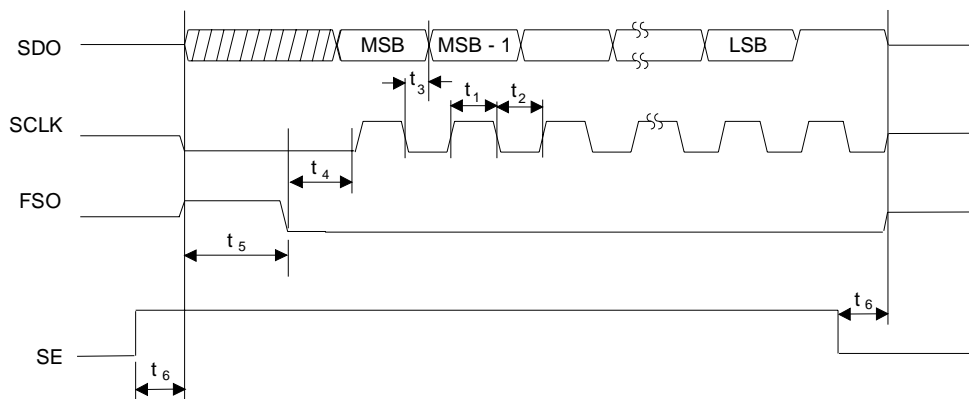

Figure 1. Serial Port Timing

2. GENERAL DESCRIPTION

The CS5471 is designed for single-phase power meter applications and interfaces to a current transformers or shunt to measure current, and a resistive divider or transformer to measure voltage.

The CS5471 combines two $\Delta\Sigma$ modulators and decimation filters, one channel assigned for current input that has programmable input gain amplifiers, and one channel assigned for voltage input.

The CS5471 includes two decimation filters that output data at a 2000 Hz or 4000 Hz output word rate (OWR).

The device outputs data on a serial output port.

2.1 Theory of Operation

The CS5471 is designed to operate from a single +3V supply and provides a ± 40 mV and ± 800 mV input range for the current channel and ± 800 mV range for the voltage channel. The CS5471 is designed to accommodate common mode + signal levels from VA- to VA+. Figure 2 illustrates the CS5471 typical inputs and power supply connections..

2.2 Performing Measurements

The converter outputs are transferred in 16-bit signed data formats as a percentage of full scale.

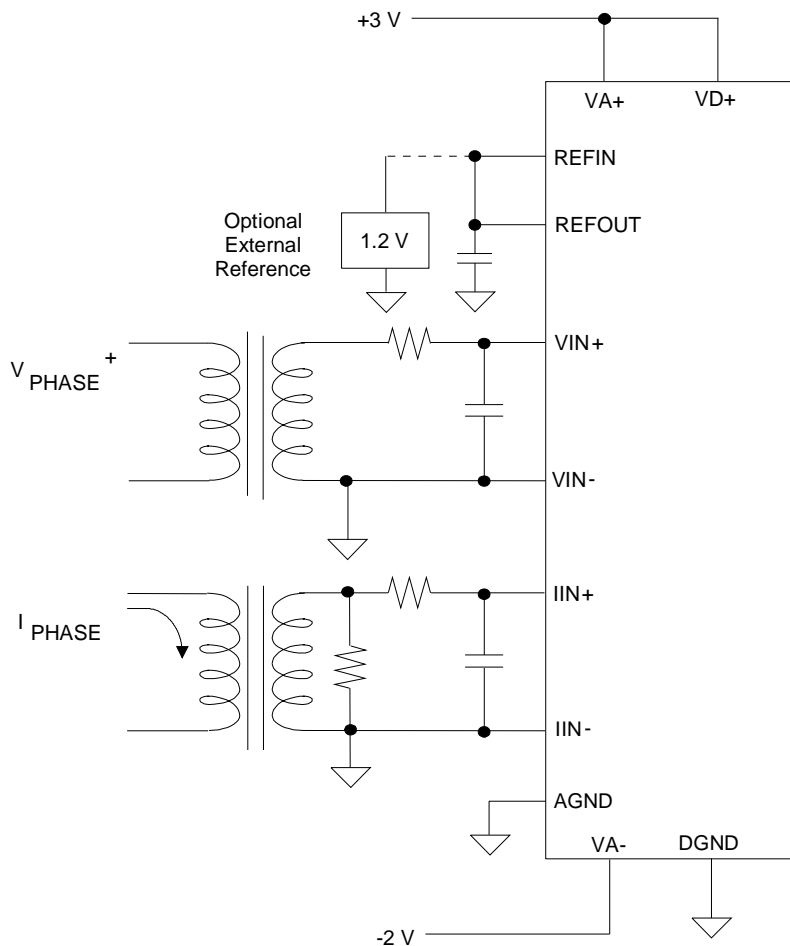

Figure 2. Typical Connection Diagram

2.3 High Rate Digital Filters

If the OWRS pin is set to logic low, the high-rate filters are implemented as fixed sinc³ filters with the following transfer function

$$H(z) = \left(\frac{1 - z^{-256}}{1 - z^{-1}} \right)^3$$

This filter samples the modulator bit stream at XIN/8 Hz and decimates to XIN/2048 Hz.

If the OWRS pin is set to logic high, then the transfer function is

$$H(z) = \left(\frac{1 - z^{-128}}{1 - z^{-1}} \right)^3$$

The above filter samples the modulator bit stream at XIN/8 Hz and decimates to XIN/1024 Hz.

2.4 Serial Interface

The CS5471 communicates with a target device via a serial data output port. Data is provided on the SDO output synchronous with the SCLK output.

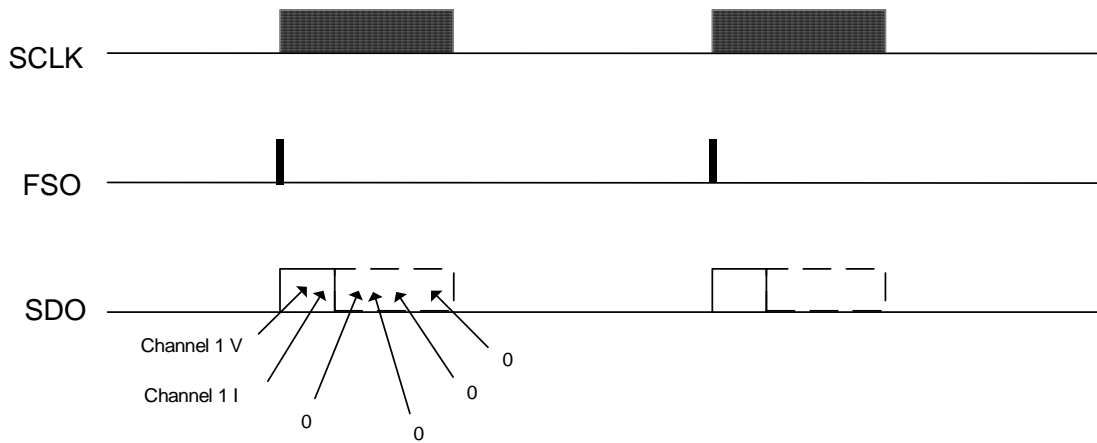

Figure 3. Serial Port Data Transfer

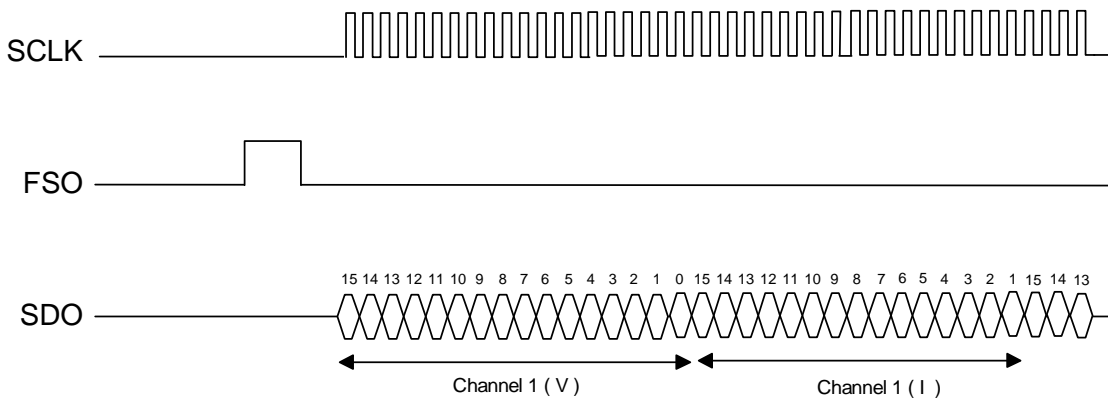

Figure 4. Close-up of One Frame

A third output, FSO, is a framing signal used to signal the start of output data. These three outputs will be driven as long as the SE (serial enable) input is held high. Otherwise, these outputs will be high impedance.

Data out (SDO) changes as a result of SCLK falling, and always outputs valid data with SCLK rising. When data is being transferred, the SCLK frequency is either 1/8 of the XIN input frequency (when OWRS is held low) or 1/4 of the XIN input frequency (when OWRS is held high). Any other time, SCLK is held low.

The framing signal (FSO) output is normally low, but produces a high level pulse lasting one SCLK period at the end of every conversion. Note that SCLK is not active during FSO high.

For 96 SCLK periods after FSO falls, SCLK is active and SDO produces valid output. Six channels of 16 bit data are output, MSB first. First, the voltage and current measurements are output (in that order). This is followed by four more 16-bit words of zero-value data. SCLK will then be held low until the next sample period.

2.5 System Initialization

When power to the CS5471 is applied, the chip must be held in a reset condition using the $\overline{\text{RESET}}$ input.

A hardware reset is initiated when the $\overline{\text{RESET}}$ pin is forced low with a minimum pulse width of 50 ns.

2.6 Analog Inputs

The analog inputs of the CS5471 are bipolar voltage inputs: One voltage channel input pair (VIN+ and VIN-) and current channel input pair (IIN+ and IIN-). The CS5471 accommodates a full scale range of ± 40 mV or ± 800 mV on the Current Channel and ± 800 mV on the Voltage Channel.

2.7 Voltage Reference

The CS5471 is specified for operation with a +1.2 V reference between the VREFIN and AGND pins. The converter includes an internal 1.2 V reference (50 ppm/ $^{\circ}\text{C}$ drift) that can be used by connecting the VREFOUT pin to the VREFIN pin of the device. If higher accuracy/stability is required, an external reference can be used.

2.8 Power Supply

Charge Pump.

The low, stable analog power consumption and superior supply rejection of the CS5471 allow for the use of a simple charge-pump negative supply generator. The use of a negative supply alleviates the need for level shifting of the analog inputs. The CPD pin and capacitor C1 provide the necessary analog supply current as shown in figure 4. The schottky diodes D1 and D2 are chosen for their low forward voltages and high-speed capabilities. The capacitor C2 provides the required charge storage and bypassing of the negative supply. The CPD output signal provides the charge pump driver signal. The frequency of the charge pump driver signal is synchronous to XIN. The nominal average frequency is 1 Mhz. The level on the VA- pin is fed back internally so that the CPD output will regulate the VA- level to $-2/3$ of VA+ level.

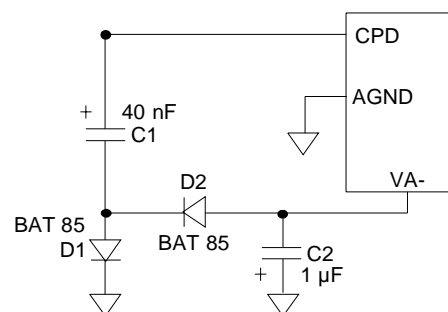

Figure 5. Generating VA- with a Charge Pump

3. PIN DESCRIPTION

Serial Clock	SCLK	□ 1 • 20 □	VD+	Digital Supply
Serial Data Output	SDO	□ 2 19 □	DGND	Digital Ground
Frame Sync	FSO	□ 3 18 □	CPD	Charge Pump Drive
Serial Port Enable	SE	□ 4 17 □	XIN	Master Clock
Current Input Gain	GAIN	□ 5 16 □	RESET	Reset
Analog Ground	AGND	□ 6 15 □	OWRS	Output Word Rate Select
Reference Input	VREFIN	□ 7 14 □	VIN+	Differential Voltage Input 1
Reference Output	VREFOUT	□ 8 13 □	VIN-	Differential Voltage Input 1
Positive Analog Supply	VA+	□ 9 12 □	IIN+	Differential Current Input 1
Negative Analog Supply	VA-	□ 10 11 □	IIN-	Differential Current Input 1

Clock Generator

XIN - Master Clock Input

Control Pins and Serial Data I/O

SE - Serial Port Enable.

When SE is low, the output pins of the serial port are 3-stated.

SDO - Serial Port Output.

Data will be at a rate determined by SCLK.

FSO - Frame Signal Output.

Framing signal output for data transfer from SDO pin.

SCLK - Serial Clock Output.

A clock signal on this pin determines the output rate of data for SDO pin. Rate of SCLK is determined by XIN frequency and state of OWRS input pin.

RESET - Reset.

When reset is taken low, all internal registers are set to their default states.

GAIN - Input Gain Control.

Sets input gain for current channel. A logic high sets internal gain to 1, a logic low level sets the gain to 20. If no connection is made to this pin, it will default to logic low level (through internal 200K resistor to DGND).

OWRS - Output Word Rate Select.

When OWRS is set to logic low, the output word rate (OWR) at SDO pin is XIN/2048 (Hz). When set to logic high, the OWR at SDO pin is XIN/1024 (Hz). If no connection is made to this pin, then OWRS will default to logic low level (through internal 200K resistor to DGND).

Measurement and Reference Input

IIN+, IIN- - **Differential Current Input.**

Differential analog input pins for current channel.

VIN+, VIN- - **Differential Voltage Inputs.**

Differential analog input pins for voltage channel.

VREFOUT - **Voltage Reference Output.**

The on-chip voltage reference is output from this pin. The voltage reference has a nominal magnitude of 1.2 V and is referenced to the AGND pin on the converter.

VREFIN - **Voltage Reference Input.**

The voltage input to this pin establishes the voltage reference for the on-chip modulator.

Power Supply Connections

VA+ - **Positive Analog Supply.**

The positive analog supply is nominally +3 V \pm 10% relative to AGND.

VA- - **Negative Analog Supply.**

The negative analog supply is nominally -2 V \pm 10% relative to AGND.

AGND - **Analog Ground.**

The analog ground pin for input signals.

VD+ - **Positive Digital Supply.**

The positive digital supply is nominally +3 V \pm 10% relative to DGND.

DGND - **Digital Ground.**

The digital ground is typically at the same level as AGND.

CPD - **Charge Pump Drive**

This output pin drives the external charge pump circuitry to create a negative supply voltage.

4. PACKAGE DIMENSIONS

20L SSOP PACKAGE DRAWING

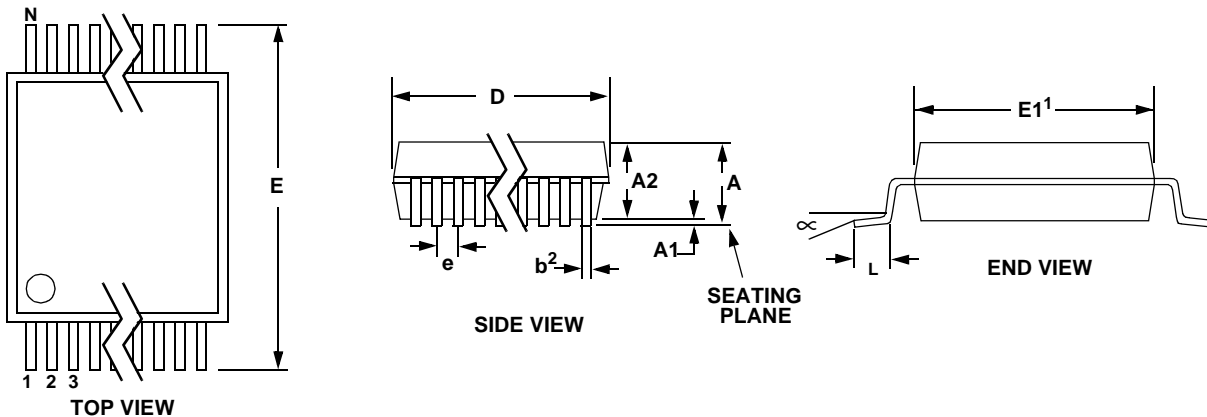

DIM	INCHES			MILLIMETERS			NOTE
	MIN	NOM	MAX	MIN	NOM	MAX	
A	--	--	0.084	--	--	2.13	
A1	0.002	0.006	0.010	0.05	0.13	0.25	
A2	0.064	0.068	0.074	1.62	1.73	1.88	
b	0.009	--	0.015	0.22	--	0.38	2,3
D	0.272	0.2834	0.295	6.90	7.20	7.50	1
E	0.291	0.307	0.323	7.40	7.80	8.20	
E1	0.197	0.209	0.220	5.00	5.30	5.60	1
e	0.022	0.026	0.030	0.55	0.65	0.75	
L	0.025	0.03	0.041	0.63	0.75	1.03	
∞	0°	4°	8°	0°	4°	8°	

JEDEC #: MO-150

Controlling Dimension is Millimeters.

- Notes:
1. "D" and "E1" are reference datums and do not include mold flash or protrusions, but do include mold mismatch and are measured at the parting line, mold flash or protrusions shall not exceed 0.20 mm per side.
 2. Dimension "b" does not include dambar protrusion/intrusion. Allowable dambar protrusion shall be 0.13 mm total in excess of "b" dimension at maximum material condition. Dambar intrusion shall not reduce dimension "b" by more than 0.07 mm at least material condition.
 3. These dimensions apply to the flat section of the lead between 0.10 and 0.25 mm from lead tips.

• **Notes** •

SMART
Analog™

This datasheet has been download from:

www.datasheetcatalog.com

Datasheets for electronics components.