

REVISION RECORD				
REV	ECN	DESCRIPTION	DRFT	DATE

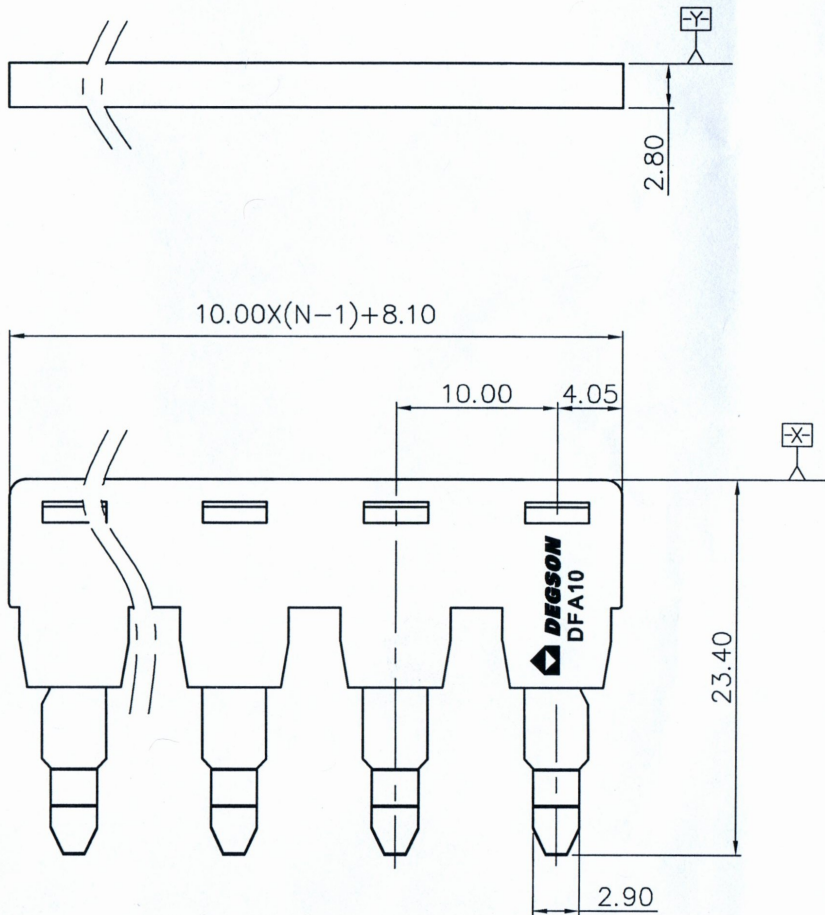

仅供参考图  
 日期: 11/16/16

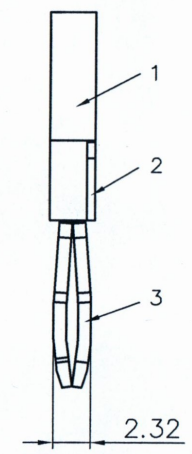

NOTES1:

- 1.Dimension shall be interpreted per ASME Y14.5-2009
- 2.Pitch : 10.0mm, Poles : N=2~10P
- 3.Operating temperature: -40°C~+105°C
- 4.Undimensioned Tolerances:

Pitch Range In mm		Nominal Dimension Range In mm				Tolerances		
TO	Over	Over	Over	Over	Over	0.1/10		
6	10	10	24	30	60	100	150	
±0.15	±0.20	±0.30	±0.30	±0.50	±0.70	±1.00	±1.30	±2'

5.RoHS Compliance

ITEM	NAME OF PART	MATERIAL	NOTES
3	Bridgware	COPPER	Sn plated
2	Cover	PA66	UL94V-0
1	Housing	PA66	UL94V-0

DETACHED LISTS	PART NO.:	宁波高松电子有限公司 NINGBO DEGSON ELECTRICAL CO., LTD		
	APPD: Alan 11/16/16	NAME: DFA10-XXP-1Y-00A(H)		
	CHKD:	TITLE: CUSTOMER DRAWING		
	DRFT: ding 03/07/16	REV	TO-1	
	THIRD ANGLE PROJECTION	DRAWING NO.: DFA10-C01	SHEET	1/1
	MM (INCH)	DO NOT SCALE DRAWING	SCALE	1:1