

受 控

# SPECIFICATION

## 1. SCOPE

This specification is applied to the piezo-element.

## 2. SPECIFICATION

(at 25°C)

- 2.1 Resonant Frequency : 3.1 ± 0.3 kHz
- 2.2 Resonant Resistace : 250 Ω max
- 2.3 Capacitance : 25000 pf ± 30% at 100Hz
- 2.4 Input Voltage : 30 Vp-p max
- 2.5 Operating Temperature : -20~+70°C
- 2.6 Storage Temperature : -30~+80°C
- 2.7 Insulation Resistance (at 25VD.C.) : 50M Ω min.

## 3. DIMENSION

: as per figure

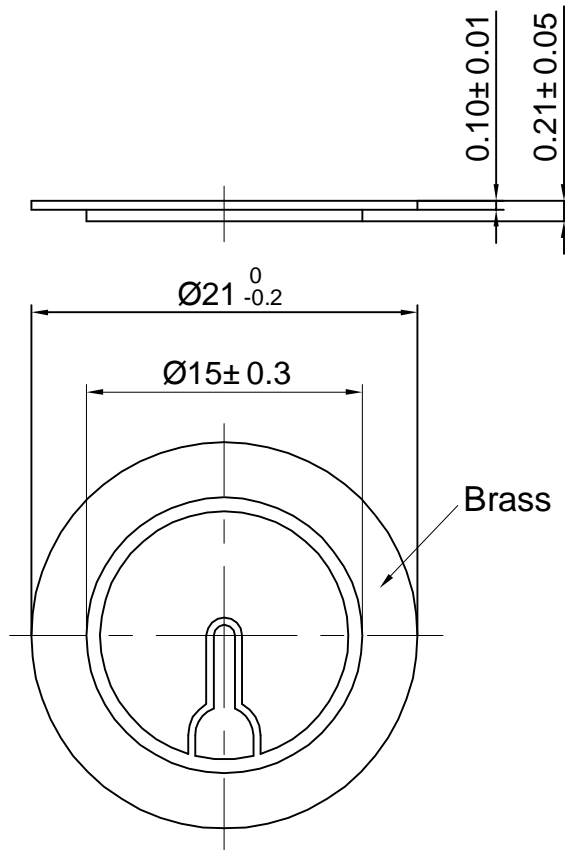

<p>TOLERANCES UNLESS NOTED OTHERWISE</p> <p>.X ±</p> <p>.XX ±</p> <p>.XXX ±</p> <p>90° FORMED +2°</p> <p>ANGLES -1°</p> <p>FIRST ANGLE PROJECTION</p>	DRAWN		KEPO MODEL NO.	CUSTOMER			
	DESIGN		<b>FT-21T-3.1B1</b>	CUSTOMER NO.			
	CHECKED			DWG NO.			
	APPROVED		<b>KP3.841.839</b>	VER	1.2	SCALE	
	DATE	14.04.29		UNIT	mm	SHEET	
	CONTRACT NO.			Ningbo Kepo Electronics Co.,Ltd.    TEL:(+86)574-88370330 FAX:(+86)574-88370329			
AGENCY APPROVAL							

1

2

3

4