

Special-purpose PCB Relay

G4A

Miniature Single-pole Relay with 80-A Surge Current and 20-A Switching Current

- Ideal for motor switching.
- Miniature, relay with high switching power and long endurance.
- Creepage distance conforms to UL and CSA standards.
- Highly noise-resistive insulation materials employed.
- Standard model available with flux protection construction.



RoHS Compliant Refer to pages 16 to 17 for details.

Ordering Information

Classification	Contact form	Model
#250 tab terminals/PCB coil terminals	SPST-NO	G4A-1A-E
PCB terminals/PCB coil terminals		G4A-1A-PE

Note: When ordering, add the rated coil voltage to the model number.
Example: G4A-1A-E 12 VDC

Rated coil voltage

Model Number Legend

G4A-□□-□□ □ VDC
1 2 3 4 5

1. Number of Poles

1: 1 pole

2. Contact Form

A: SPST-NO

3. Terminals

None: #250 tab/PCB coil terminals

P: Straight PCB/PCB coil terminals

4. Special Function

E: For long endurance

5. Rated Coil Voltage

5, 12, 24 VDC

Specifications

■ Coil Ratings

Rated voltage	5 VDC	12 VDC	24 VDC
Rated current	180 mA	75 mA	37.5 mA
Coil resistance	27.8 Ω	160 Ω	640 Ω
Coil inductance (ref. value)	Armature OFF	---	3.5 H
	Armature ON	---	4.8 H
Must operate voltage	70% of rated voltage max.		
Must release voltage	10% of rated voltage min.		
Max. permissible voltage	160% of rated voltage at (23°C)		
Power consumption	Approx. 0.9 W		

- Note:**
1. The rated current and coil resistance are measured at a coil temperature of 23°C with a tolerance of ±10%.
 2. Operating characteristics are measured at a coil temperature of 23°C.
 3. Max. permissible voltage refers to the maximum value in a varying range of operating power voltage, not a continuous voltage.

■ Contact Ratings

Rated load	20 A at 250 VAC
Rated carry current	20 A
Max. switching voltage	250 VAC
Max. switching current	20 A
Max. switching power	5,000 VA
Failure rate (reference value)	100 mA at 5 VDC

Note: P level: $\lambda_{60} = 0.1 \times 10^{-6}/\text{operation}$

■ Endurance

With Motor Load

Load conditions	Switching frequency	Electrical endurance
250 VAC: Inrush current: 80 A, 0.3 s ($\cos\phi = 0.7$) Break current: 20 A ($\cos\phi = 0.9$)	ON: 1.5 s OFF: 1.5 s	200,000 operations

With Overload

Load conditions	Switching frequency	Electrical endurance
250 VAC: Inrush current: 80 A ($\cos\phi = 0.7$) Break current: 80 A ($\cos\phi = 0.7$)	ON: 1.5 s OFF: 99 s	1,500 operations

With Inverter Load

Load conditions	Switching frequency	Electrical endurance
100 VAC; Inrush current: 200 A (0-P) Break current: 20 A	ON: 3 s OFF: 5 s	30,000 operations

■ Characteristics

Contact resistance	100 m Ω max.
Operate time	20 ms max.
Release time	10 ms max.
Max. operating frequency	Mechanical: 18,000 operations/hr
Insulation resistance	1,000 M Ω min. (at 500 VDC)
Dielectric strength	4,500 VAC 50/60 Hz for 1 min between coil and contacts 1,000 VAC 50/60 Hz for 1 min between contacts of same polarity
Vibration resistance	Destruction: 10 to 55 to 10 Hz, 0.75-mm single amplitude (1.5-mm double amplitude) Malfunction: 10 to 55 to 10 Hz, 0.75-mm single amplitude (1.5-mm double amplitude)
Shock resistance	Destruction: 1,000 m/s ² Malfunction: 200 m/s ²
Endurance	Mechanical: 2,000,000 operations min. (at 18,000 operations/hr) Motor load: 100,000 operations min. (ON/OFF: 1.5 s) Inverter load: 30,000 operations min. (ON: 3 s, OFF: 5 s)
Ambient temperature	Operating: -20°C to 60°C (with no icing)
Ambient humidity	Operating: 5% to 85%
Weight	Approx. 23 g

Note: The data shown above are initial values.

Engineering Data

Maximum Switching Power

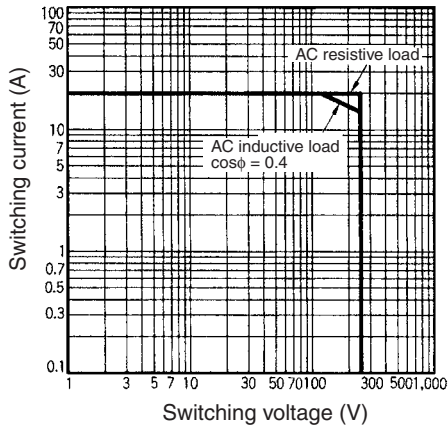

Endurance

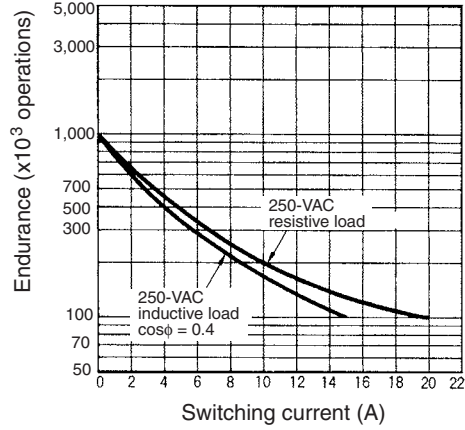

Dimensions

Note: All units are in millimeters unless otherwise indicated; dimensions shown in parentheses are in inches.

G4A-1A-E

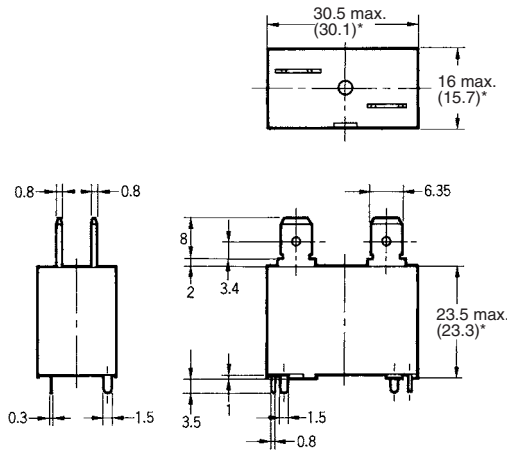
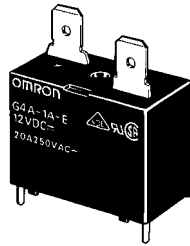

*Average value

Mounting Holes (Bottom View)

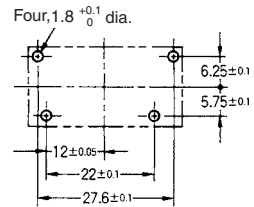

Terminal Arrangement / Internal Connections

(Top View) (Bottom View)

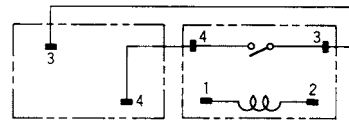

Tab Terminal PCB Terminal

G4A-1A-PE

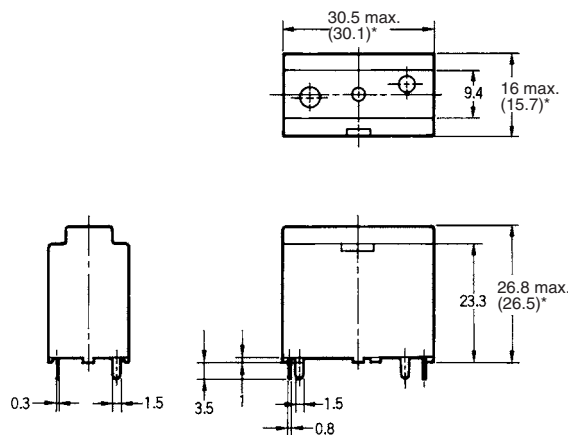

*Average value

Mounting Holes (Bottom View)

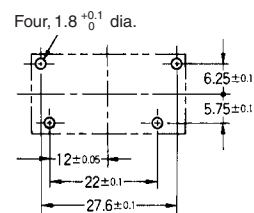

Terminal Arrangement / Internal Connections (Bottom View)

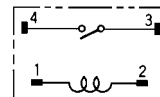

Precautions

Mounting

When mounting two or more relays side by side, provide a minimum space of 3 mm between relays.

Terminal Connection

The terminals fit FASTON receptacle 250 and are suitable for positive-lock mounting.

Do not apply excessive force on the terminals when mounting or dismounting the relay.

The following positive-lock connectors made by AMP are recommended.

Type	Receptacle terminals	Positive housing
#250 terminals (width: 6.35 mm)	AMP 170333-1 (170327-1) AMP 170334-1 (170328-1) AMP 170335-1 (170329-1)	AMP 172076-1 natural color AMP 172076-4 yellow AMP 172076-5 green AMP 172076-6 blue

Note: The numbers shown in parentheses are for air-feeding.

ALL DIMENSIONS SHOWN ARE IN MILLIMETERS.

To convert millimeters into inches, multiply by 0.03937. To convert grams into ounces, multiply by 0.03527.