



Features

- Universal AC input from 80V_{AC} to 265V_{AC}
- Efficiency > 90% when V_{AC} = 110V, I_{LED} = 350mA, 6-LED load
- Setting current accuracy within ±5%
- Driving external MOSFET current up to 3 Amperes
- Hysteretic PFM improves efficiency in light load conditions
- Full protection: Thermal/UVLO/OVP/LED Open/Short Circuit
- Available in MSOP-8L package

Mini Small Outline Package



GMS: MSOP-8L-118mil

Product Description

MBI6902 is a high efficiency step-down AC/DC controller designed to deliver constant current. The input voltage range of MBI6902 is universal from 80V_{AC} to 265V_{AC}. It is featured by a hysteretic PFM control scheme which enhances the efficiency in light load conditions. MBI6902 regulates the output current within ±5% of the preset current by well controlling the external MOSFET. In addition, LED dimming control can be implemented by connecting the output of a photocoupler to the DIM pin. MBI6902 is also characteristic of protecting the controller from fault conditions, inclusive of under voltage lock-out (UVLO) and over voltage protection (OVP). To ensure system reliability, thermal protection (TP) is built-in to prevent IC from over temperature (155°C) by turning off the external MOSFET. Once the temperature drops below 125°C, the external MOSFET will resume working. MBI6902 is available in MSOP-8L package.

Applications

- T-8 CFL Replacement LED Solution
- E26/E27 Light Bulb Alternative LED Solution
- General Illuminations
- Power Supply for Light Panel

Typical Application Circuit

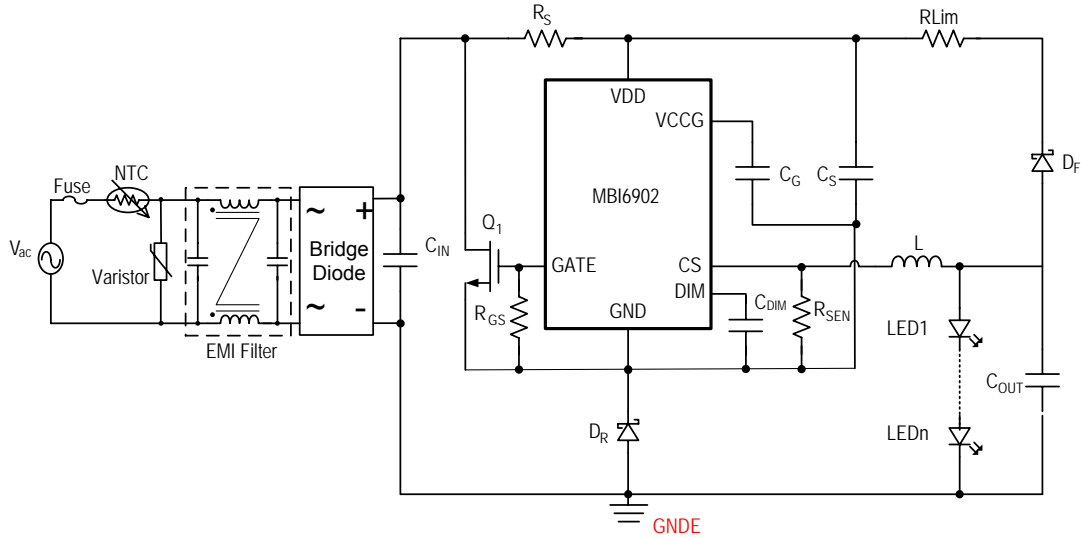

Note: GND and GNDE **CAN NOT** directly connect together to avoid IC damage and system malfunction.

Figure 1

- C_{IN}: 10μF/400V, 105 5000hrs electrolytic capacitor
- C_{OUT}: 10μF/400V, 105 5000hrs electrolytic capacitor
- D_R: 600V/1A, ultrafast diode
- D_F: 600V/1A, ultrafast diode
- L: 1.0mH, 14*15 power inductor
- R_S: 1MegΩ, resistor (sustaining voltage at least 400V)
- R_{LIM}: 12Ω, SMD resistor
- R_{GS}: 20kΩ, SMD resistor
- C_S: 1μF/50V, ceramic capacitor
- C_G: 0.2μF/25V, ceramic capacitor
- Q1: 600V/3.3A, N-channel MOSFET

Functional Diagram

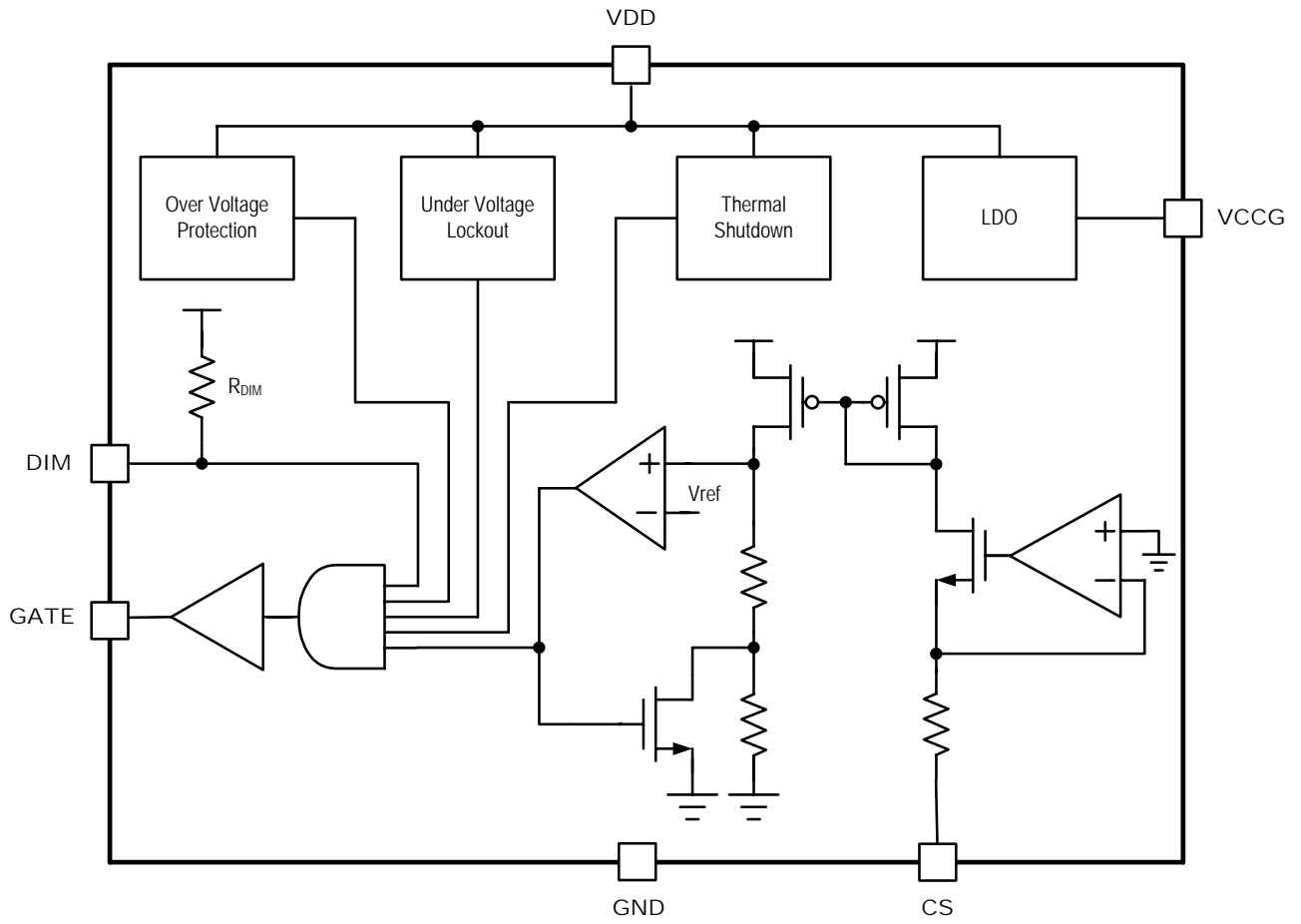
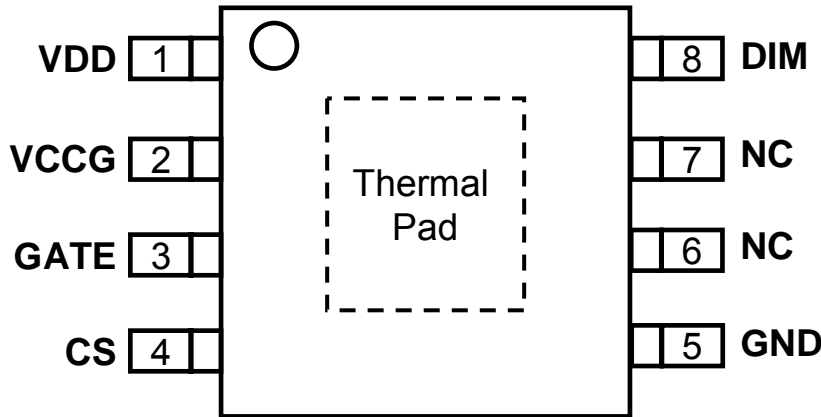

Figure 2

Pin Configuration



MSOP-8L (Top View)

Pin Description

Pin Name	Pin No.	Function
VDD	1	Supply voltage terminal and over-voltage protection
VCCG	2	Terminal to connect a capacitor to enhance the stability of VCCG
GATE	3	Terminal to drive the gate of the external MOSFET
CS	4	Terminal to sense LED string current
GND	5	Ground terminal for control logic and current sink
NC	6, 7	No connection
DIM	8	Terminal for dimming control. If the dimming function is unused, this pin can be kept floating.
Thermal Pad	-	Power dissipation terminal connected to GND*

*To eliminate the noise impact, the thermal pad should connect to GND (Pin No. 5) on PCB. In addition, a heat-conducting copper foil on PCB soldered with thermal pad will improve thermal conductivity.

Absolute Maximum Ratings

Operation above the maximum rating may cause device failure and affect the device reliability.

Characteristic		Symbol	Rating	Unit
Supply Voltage		V_{DD}	-0.4~44	V
Thermal Resistance (By simulation, on 4 Layer PCB)*	GMS Type	$R_{th(j-a)}$	38.93	°C/W
Operating Junction Temperature		$T_{j,max}$	125	°C
Operating Temperature		T_{opr}	-40~+85	°C
Storage Temperature		T_{stg}	-55~+150	°C

* The PCB size is 76.2mm*114.3mm in simulation.

Electrical Characteristics

Test condition: $V_{DD}=12V$, $C_{IN}=1\mu F$, $C_{OUT}=0.5nF$, $T_A=25^\circ C$; unless otherwise specified.

Characteristics	Symbol	Condition	Min.	Typ.	Max.	Unit
Supply Voltage	V_{DD}	-	9	-	40	V
Quiescent Current	I_{DD1}	The current before start-up voltage	-	20	30	μA
	I_{DD2}	Switching frequency = 100KHz, driving 0.5nF load at gate terminal	-	2.5	4.0	mA
HYSTERESIS CONTROL						
Sense Regulation Threshold Voltage	V_{CSH}	Change V_{CS} until $V_{GATE}=\text{High}$ refer to Figure 3	-	-100	-	mV
Sense Over Current Threshold Voltage	V_{CSL}	Change V_{CS} until $V_{GATE}=\text{Low}$ refer to Figure 3	-	-300	-	mV
Threshold Hysteresis of V_{CS}	V_{SENHYS}	-	-	50	-	%
Input Current of V_{CS}	I_{SEN}	$V_{CS} = -0.2V$	20	40	60	μA
Internal Propagation Delay Time	T_{PDHL}	V_{CS} to GATE loop delay from high to low, $V_{DD}=12V$, $V_{CS} = -0.15V$ to $-0.25V$, $C_{OUT}=0.5nF$	-	150	300	ns
	T_{PDLH}	V_{CS} to GATE loop delay from low to high, $V_{DD}=12V$, $V_{CS} = -0.15V$ to $-0.25V$, $C_{OUT}=0.5nF$	-	150	300	ns
GATE DRIVER						
Output Voltage of Gate	V_{GATE}	-	7.0	7.5	7.8	V
Gate Driver Rising Time	t_{RISE}	$C_{OUT} = 0.5nF$	-	30	60	ns
Gate Driver Falling Time	t_{FALL}	$C_{OUT} = 0.5nF$	-	30	60	ns
Leading Edge Blanking Period	t_{BLANK}	$C_{OUT} = 0.5nF$		500		ns
THERMAL OVERLOAD						
Thermal Shutdown Threshold	T_{SD}	-	145	155	175	$^\circ C$
Thermal Shutdown Hysteresis	T_{SD-HYS}	-	-	30	-	$^\circ C$
START-UP & UNDER VOLTAGE LOCKOUT						
Start-up Voltage	$V_{Start-up}$	-	15	16	17	V
UVLO Voltage	V_{UVLO}	-	7.5	8.0	8.5	V
OVER VOLTAGE PROTECTION						
Over Voltage Protection	V_{OVP}	-	41	44	48	V
PWM DIMMING						
Digital Dimming Logic	"H" level	V_{DIMIH}	-	3.5	-	V
	"L" level	V_{DIMIL}	-	-	0.5	V
Internal Pull-up Resistor	R_{DIM}	-	-	100	-	K

Test Circuit for Electrical Characteristics

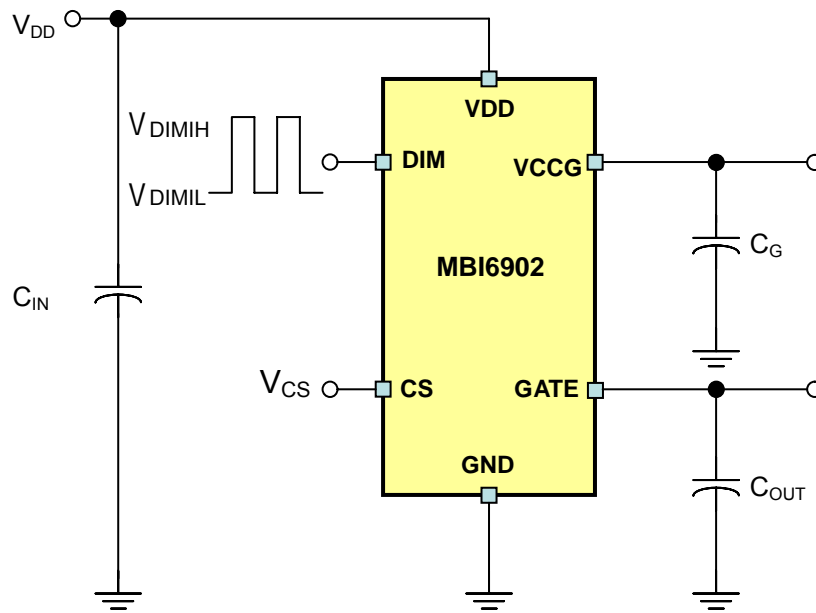

Figure 3

Application Information

MBI6902 is a universal ac input AC/DC constant current LED driver designed for high power LED applications. In the application circuit, there are distinct grounds, namely GND and GNDE. GND is the reference ground for internal circuit while GNDE is the earth ground. Users should be aware that GND and GNDE **CAN NOT** be directly connected together to avoid IC damage and system malfunction.

Start-Up and UVLO (Under Voltage Lock-Out)

When power is on, the voltage imposed on C_{IN} will charge C_S , which is parallel to MBI6902, through R_S . The time for charging up C_S to $V_{Start-up}$ is the start-up time. The $V_{Start-up}$ is designed as 16V. MBI6902 is also equipped with UVLO protection. When V_{DD} is below the UVLO threshold of 8V (typ.), UVLO starts working and MBI6902 will be disabled, as shown in Figure 4. The hysteresis of UVLO is 8V. Once the input voltage reaches $V_{Start-up}$ again, MBI6902 resumes working and starts regulating the output current to its preset value.

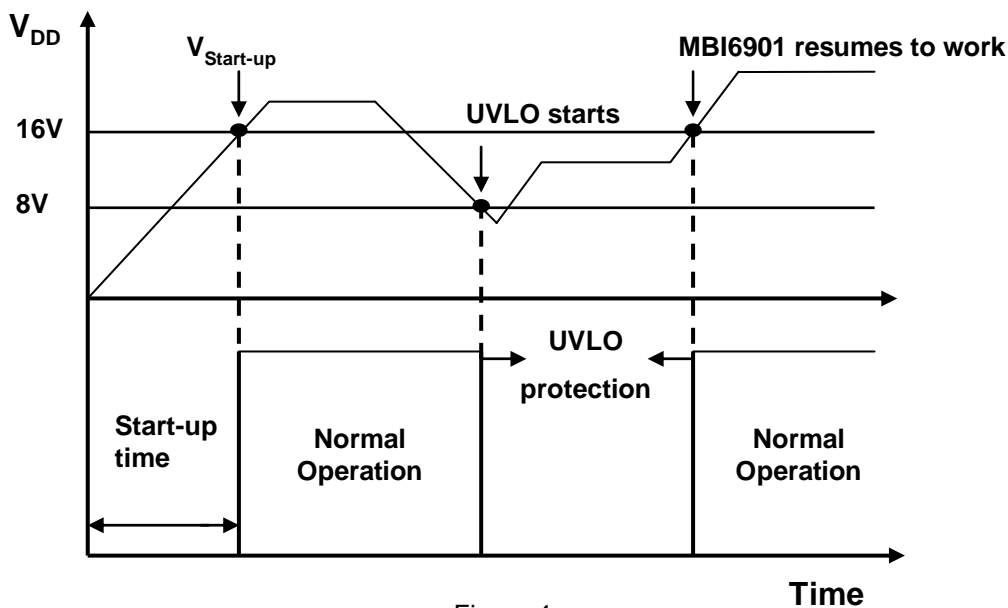

Figure 4

Setting Output Current

The output current I_{OUT} is set by an external resistor R_{SEN} . The relationship between I_{OUT} and R_{SEN} is defined as:

$$V_{CS} = -0.2V;$$

$$R_{SEN} = V_{CS} / I_{OUT} = 0.2V / I_{OUT};$$

$$I_{OUT} = V_{CS} / R_{SEN} = 0.2V / R_{SEN}$$

where R_{SEN} is the resistance of the external resistor connected between CS and GND. V_{CS} is the voltage across the resistor R_{SEN} . The magnitude of LED current (as a function of R_{SEN}) is around 350mA for $R_{SEN} = 0.57 \Omega$.

Hysteresis Operation

In MBI6902, V_{CS} is designed with a $\pm 50\%$ hysteresis, leading to the same percentage of LED current ripple. The operation of MBI6902 is based on the hysteretic PFM control scheme, and therefore the operating frequency remains relatively constant against load and line voltage variations. The hysteretic PFM control requires no loop compensation and therefore realizes fast load transient response and achieves excellent efficiency performance in light load conditions.

Dimming Control

Due to the system topology, it is a must to apply a photocoupler for LED dimming when a PWM signal is applied as the dimming control, as shown in Figure 5. It is suggested that users add a ceramic capacitor (C_{DIM}) to filter out noise when the photocoupler is coupled to DIM pin. Also, a $R_{PULL-UP}$ to speed up IC dimming is also recommended. Users can refer to the Application Note of MBI6902 for more insights into dimming control.

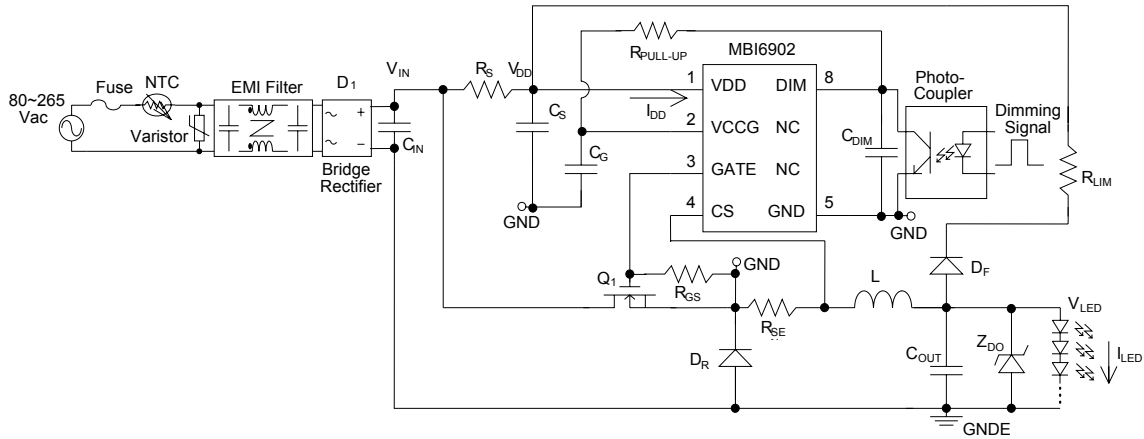

Figure 5

OVP (Over Voltage Protection)

When V_{DD} rises above the OVP threshold of 44V, GATE is forced low to turn off the external power MOSFET. GATE will not be pulled high until V_{DD} falls below 23V. This function prevents the driver from suffering high voltage stress and also protects LEDs. The threshold also limits the V_{LED} headroom and LED numbers that can be lit up.

LED Open-Circuit Protection

When any LED connected to MBI6902 is open-circuited, it will trigger OVP to turn off the external power MOSFET and therefore no current is supplied to LEDs.

LED Short-Circuit Protection

When any LED connected to MBI6902 is short-circuited, MBI6902 adaptively regulates the output current according to the new loading.

TP Function (Thermal Protection)

When the junction temperature exceeds the threshold T_{SD} of 155°C, MBI6902 turns off the external power MOSFET. Thus, the junction temperature starts to decrease. Once the junction temperature drops below 125°C, the external power MOSFET will resume its normal operations.

Design Example

Here is a reference design for MBI6902. This design example is based on the following parameters.

The input voltage of the target specification ranges from 80V_{AC} to 265V_{AC}.

The target LED current is 350mA.

The number of LED in series is 6pcs, and the forward voltage of a single LED is 3.72V.

Select LED Current

The LED current (I_{LED}) is set by R_{SEN}

Where R_{SEN} = 0.2V/0.35A = 0.57Ω.

Choose R_{SEN} = 0.56Ω.

Therefore, the power dissipation of P_{RSEN} = (0.2V)² / 0.56Ω = 0.0224W. It is suggested to use a R_{SEN} resistor of 0.56Ω/0.25W with less than 1% deviation. The resulting LED current is modified as I_{LED} = 0.2V/ 0.56Ω = 357mA.

Select the Inductor (L) and Switching Frequency (f_{sw})

The inductance is determined by two parameters: the switching frequency and the inductor current ripple. The calculation of the inductance L can be described as follow

$$L = \frac{(V_{IN} - V_{LED}) \times D}{f_{SW} \times \Delta I_{LED}}$$

where D is the duty cycle of MBI6902, D=V_{LED}/V_{IN}, f_{SW} is the switching frequency of the MBI6902, and I_{LED} is the current ripple of the inductor. In MBI6902, the hysteresis is 50%, and consequently,

$$I_{LED} = (1.50 \times I_{LED}) - (0.50 \times I_{LED}) = 1.0 \times I_{LED}$$

To eliminate audio noise and overheating of power MOSFET (Q₁), it is recommended that f_{SW} be set within 25kHz to 100kHz. To comply with this constraint, the selections of the inductor L and switching frequency f_{SW} are calculated as follows.

$$L_{REC-MAX} = \{[(80V \times \sqrt{2}) - (3.72 \times 6)] \times [(3.72 \times 6) / (80V \times \sqrt{2})]\} / [1.0 \times 25e+3 \times 0.357] = 2.01 \text{ mH}$$

$$L_{REC-MIN} = \{[(265V \times \sqrt{2}) - (3.72 \times 6)] \times [(3.72 \times 6) / (265V \times \sqrt{2})]\} / [1.0 \times 100e+3 \times 0.357] = 0.59 \text{ mH}$$

Choose the inductor L = 1.0 mH,

Choose the saturation current 1A and DCR=0.64Ω.

$$f_{SW, MIN} = \{[(80V \times \sqrt{2}) - (3.72 \times 6)] \times [(3.72 \times 6) / (80V \times \sqrt{2})]\} / [1.0 \times 1.0e-3 \times 0.357] = 50.19\text{kHz}$$

$$f_{SW, MAX} = \{[(265V \times \sqrt{2}) - (3.72 \times 6)] \times [(3.72 \times 6) / (265V \times \sqrt{2})]\} / [1.0 \times 1.0e-3 \times 0.357] = 58.80\text{kHz}$$

Select Bridge Diode and Power MOSFET (Q1)

The voltage rating of the bridge diode depends on the maximum value of the input voltage. It is reasonable to choose 1.2 times of V_{IN, MAX}. for safety margin. Therefore, a 600V/1A bridge diode is enough.

$$V_{BRIDGE} = 1.2 \times \sqrt{2} \times V_{IN, MAX} = 1.2 \times \sqrt{2} \times 265 = 450V$$

In this example, we adopt the bridge with a rating of 1000V/1.5A and forward voltage of 1.1V. Similar to the bridge diode, the voltage rating of the power MOSFET can follow the calculation above.

In typical applications of MBI6902, the output current usually ranges from 350mA to 1000mA. The 600V/2A MOSFET or MOSFET with higher ratings is desirable. It is recommended to minimize conduction loss by choosing

the power MOSFET with low turn-on resistance. In this design example, the rating of the power MOSFET is 600V/3.3A.

Gate Discharge Resistor, R_{GS}

In this example, the recommended resistance for R_{GS} is 20k Ω .

Select Freewheeling Diode (D_R and D_F)

In this example, the adopted diode has the specification of a reverse breakdown voltage of 600V, forward current of 1A, and a forward voltage of 1.7V. The voltage rating of the freewheeling diode depends on the maximum value of the input voltage. It is reasonable to choose 1.2 times of $V_{IN,MAX}$ for safety margin, and the criterion for selecting D_R and D_F is,

$$1.2 \times \sqrt{2} \times V_{IN,MAX} = 1.2 \times \sqrt{2} \times 265 = 450V$$

Therefore, a 600V/1A ultrafast diode satisfies the design requirement.

Select Current Limit Resistor (R_{LIM}) (Optional)

The purpose of the R_{LIM} is to protect D_F . In this design example, $R_{LIM} = 12 \Omega$ is suggested.

Select Input Capacitor (C_{IN})

The rated voltage of input capacitor should be at least 1.2 times of the maximum input voltage. An electrolytic capacitor can be used as an input capacitor, and the recommended ratings are 10 μ F/400V for $I_{LED}=350mA$ and 22 μ F/400V for $I_{LED}>700mA$.

Select Output Capacitor (C_{OUT}) (Optional)

A capacitor paralleled to the cascaded LEDs can reduce the LED current ripple. An electrolytic capacitor with a rating of 10 μ F/400V can be used for this purpose.

Select Fuse, NTC, Varistor and EMI Filter

Please refer to MBI6902 Application Note and Design Tool for the selections of fuse, NTC and varistor. The EMI filter is optional. Therefore, users should optimize the EMI filter parameters based on each application.

Package Power Dissipation (PD)

The maximum power dissipation, $P_D(max)=(T_j-T_a)/R_{th(j-a)}$, decreases as the ambient temperature increases.

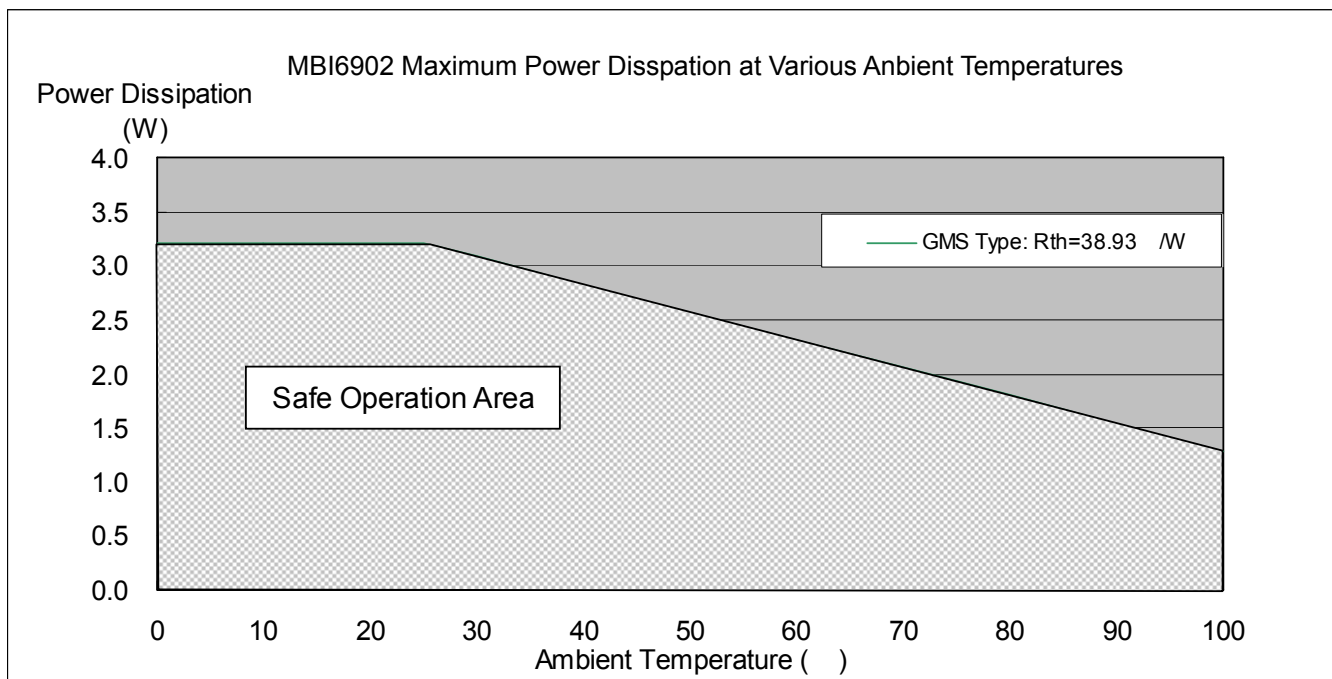

Outline Drawing

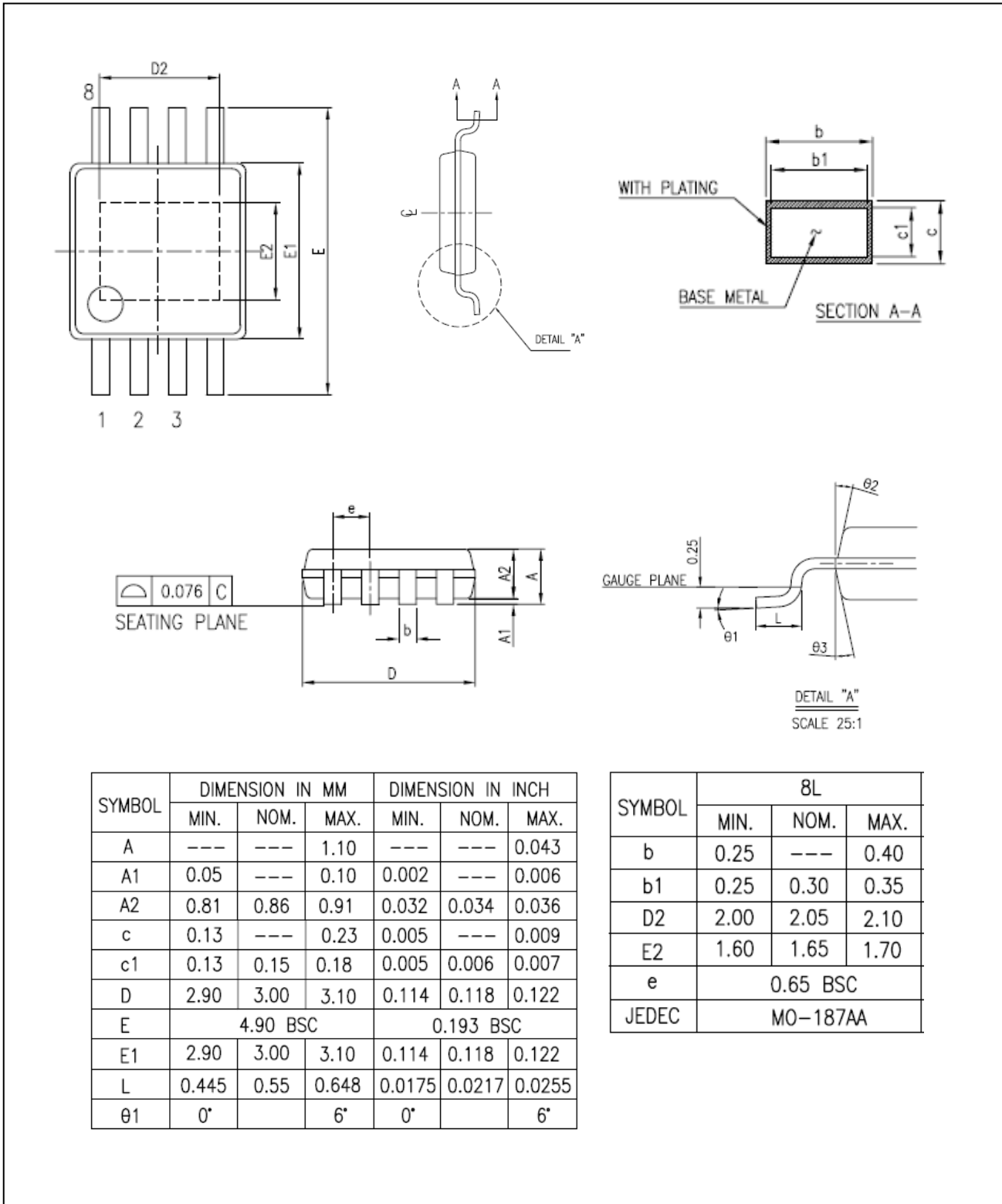

MBI6902 GMS Outline Drawing

Note: The unit for the outline drawing is millimeter (mm). Please use the maximum dimensions for designing the thermal pad layout. To avoid the short circuit risk, the vias or circuit traces shall not pass across the maximum area of thermal pad.

Product Top Mark Information

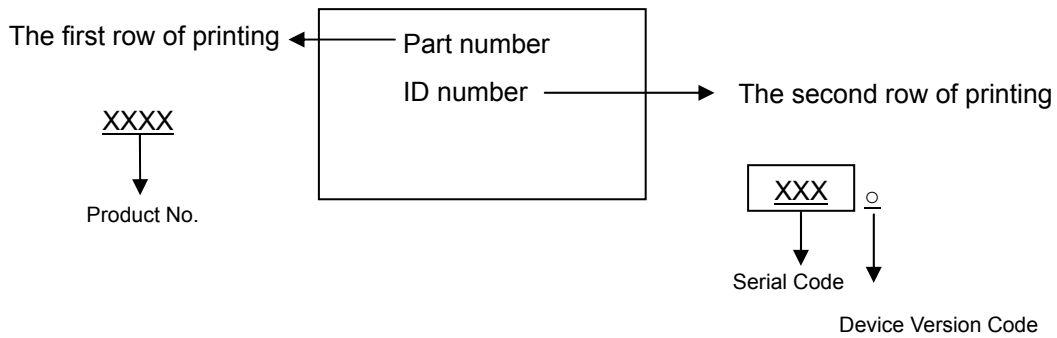

Product Revision History

Datasheet version	Device Version Code
V1.00	A

Product Ordering Information

Part Number	"Pb-free" Package Type	Weight (g)
MBI6902	GMS: MSOP-8L-118mil	0.023 g

Disclaimer

Macroblock reserves the right to make changes, corrections, modifications, and improvements to their products and documents or discontinue any product or service without notice. Customers are advised to consult their sales representative for the latest product information before ordering. All products are sold subject to the terms and conditions supplied at the time of order acknowledgement, including those pertaining to warranty, patent infringement, and limitation of liability.

Macroblock's products are not designed to be used as components in device intended to support or sustain life or in military applications. Use of Macroblock's products in components intended for surgical implant into the body, or other applications in which failure of Macroblock's products could create a situation where personal death or injury may occur, is not authorized without the express written approval of the Managing Director of Macroblock.

Macroblock will not be held liable for any damages or claims resulting from the use of its products in medical and military applications.

All text, images, logos and information contained on this document is the intellectual property of Macroblock.

Unauthorized reproduction, duplication, extraction, use or disclosure of the above mentioned intellectual property will be deemed as infringement.