

MASTECH® MS2009A

Multifunction Digital Clamp Meter User Manual

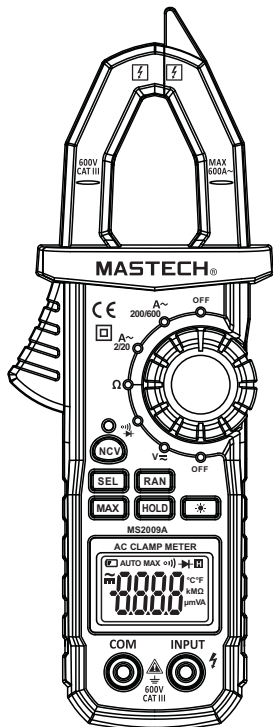

CE

CONTENTS

Safety requirements.....	1
Safety signs.....	1
Notes.....	1
Maintenance.....	2
Overview.....	3
Meter Indications.....	3
Schematic Drawing For Panel.....	5
Instructions.....	6
Accuracy Indicators.....	10
Automatic Power-Off.....	13
Replace Battery.....	13
Accessories.....	14

Safety Requirements

The MS2009A digital clamp meter has been designed according to Safety Standard IEC61010-1 IEC61010-2-032 for electronic measuring instruments and hand-held current clamps. It conforms to safety standards for double insulation CAT III 600 V and grade 2 for pollution.

Safety Signs

 Important safety sign. Refer to the operation manual.

 Danger high voltage.

 Allow to be used around conductors without danger to life.

 Double insulation (Safety equipment with class II).

 Ground (earth).

Notes

- Before using this meter, please read carefully this user manual and pay special attention to “warning” content. Please follow the “warning” instructions.
- To meet the safety requirements, only use probe supplied with the meter. If the probe is replaced, a new one with the same model or same electric specification should be used.
- Before using it, please check the meter and probe for any damage or abnormal condition. If an abnormal situation appears (for example: bare probe, enclosure damage, no liquid crystal display, etc), don't use the meter.

- When the meter is measuring, don't touch the unused input terminal.
- Be careful when measuring voltage greater than 60V DC and 30V AC. Don't allow fingers to touch or block part of the probe.
- When you can't determine the size range of signal to be tested, please switch the function measuring range to the maximum position, then gradually select lower ranges until the correct range is found. Do not exceed the input limit specified in each measuring range.
- Don't measure voltage greater than the upper limit for each range.
- Before changing the function measuring range switch to a different position, set the probe and the circuit being tested to an open state.
- Before online resistance measurement, turn off all power supplies in circuit and release all charges on both ends of capacitor.
- Don't expose the meter exposure to strong light, high temperature or moisture (humidity).
- Don't touch bare wires, connectors or circuits being measured.

Maintenance

- Before opening the meter back cover, make sure that the probe is removed from the circuit to be measured.
- Only wet cloth and a small amount of detergent can be used for cleaning the meter. Don't use chemical solvents to wipe the meter case.
- If you find any abnormal condition on the meter, stop using the meter immediately and have it repaired.
- Repair the meter with the help of a trained technician.

Overview

The MS2009A is a safe and reliable digital clamp meter with stable performance. Its design is based on a large scale integrated circuit double integral A/D converter, with full measuring range of overload protection circuit. With a unique appearance, it is a special electrical meter with superior performance. The MS2008A can be used for measuring AC current, AC/DC voltage, resistance, diode, circuit continuity test, and non-contact voltage detection.

Meter Indications

1. AC current clamp head

Pick AC current

2. NCV indicator light

When the voltage of conductor under test is more than AC 90V, the indicator will flash constantly.

3. SEL function exchange key

When it is in $V \approx$ position, it is used to switch between DCV and ACV .

When it is in \rightarrow position, it is used to switch between diode measurement and continuity measurement.

4. Display

LCD display (4 significant digits).

5. COM input end

In addition to AC current, negative input end of black probe.

6. INPUT end

Red probe positive input end when measuring voltage, resistance, diode forward voltage drop and circuit continuity.

7. Function measuring switch

Used to select each function and measuring range grade.

8. Clamp head center position

To improve current measurement accuracy, place the conductor to be measured in the center position.

9. NCV sense position

When detecting non-contact voltage, position close to the conductor to be tested

Other Keys

☀ Backlight

The meter display is set with backlight. Press the key for 2 seconds to light. Press the key for 2 seconds again to turn off the backlight.

HOLD data hold key

Press "HOLD" key. The meter display will keep the last test reading; and show "H" symbol. Press "HOLD" key again and the meter will restore to normal measuring state.

RAN Manual/Automatic Switch Key

In voltage and resistance measurement position, clamp meter is set to automatic measuring range by default. Press this key to switch to manual measuring range. In the manual measuring range mode, click the key once to jump to upper grade. If it is at the top grade, then it will jump to the bottom grade. Hold this key for 2 seconds to switch back to automatic measuring range.

MAX Maximum reading value display

Press "MAX" key. The display will show the maximum reading value among measuring data. Press the "MAX" key again. The meter will revert to normal measurement state

NCV Non-contact voltage detection switch Used for non-contact voltage detection.

Schematic Drawing For Panel

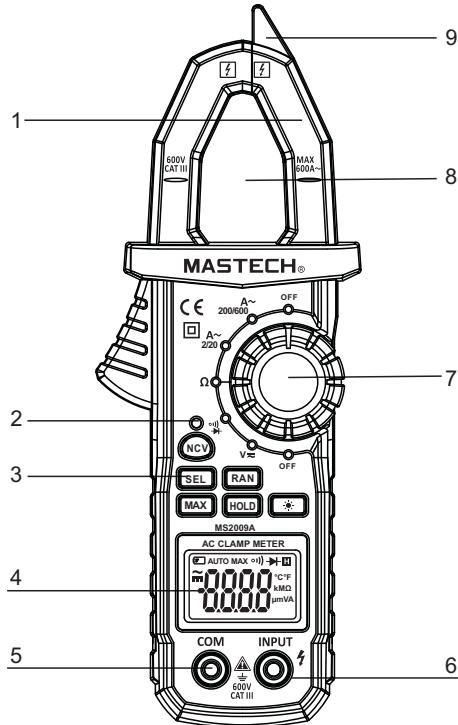

Instructions

DC Voltage Measurement

1. Insert red probe to "INPUT" jack and insert black probe to "COM" jack.
2. Place function measuring range switch to DC voltage measuring range. Press "SEL" key, and connect the probe to the power source or load to be tested. The polarity of the end connected with red probe will be shown in the display at the same time.
3. Read the measuring result from display.

Notes!

- Δ If the range of voltage to be tested is not known in advance, place function measuring switch to the maximum range, then gradually reduce to obtain the correct range.
- Δ Pay special attention to avoid shock when measuring high voltage.

AC Voltage Measurement

1. Insert red probe to "INPUT" jack and insert black probe to "COM" jack.
2. Place function measuring range switch to AC voltage measuring range, and connect the probe to the power source or load to be tested. The polarity of the end connected with red probe will be shown in the display at the same time.
3. Read the measuring result from display.

Notes!

- Δ Pay special attention to avoid shock when measuring high voltage.

AC Current Measurement

1. Place function measuring range switch to AC current measuring range.
2. Press the trigger, open clamp head, clip the lead in the clamp to measure the lead current. Note: Clamping two or more leads at the same time will give invalid reading.
3. Read the measuring result from display.

Note:

△ If the range of current to be tested is not known in advance, please place function measuring switch to the maximum current range, then gradually reduce to obtain the correct range.

Resistance Measurement

1. Insert red probe and black probe to "INPUT" and "COM" jack.
2. Place function measuring range switch to required Ω position, and connect the probe to resistor to be tested.
3. Read the measuring result from display.

Note:

- △ If measured resistance value is more than the maximum value of chosen measuring range, it will show "OL". At this time, select a higher range.
- △ When checking online resistance, first turn off all power supplies in the circuit to be measured and discharge all capacitors fully.
- △ When measuring the resistance more than $1M\Omega$, the reading will be stable after several seconds. This is normal for high resistance measuring.

Diode Test

Insert red probe to "INPUT" and insert black probe to "COM" jack. At this time, red probe polarity is "+". Place function measuring switch to $\rightarrow|$ position. Red probe is connected to the anode of diode under measurement, and black probe is connected to the cathode of diode under measurement. Read approximate forward voltage drop value from the display.

Circuit Continuity Test

Insert red probe to "INPUT" jack, and insert black probe to "COM" jack. Place function measuring switch to $\rightarrow|$ position and press SEL key to enter circuit continuity test. Probe is connected to two points of circuit under measurement. In continuity test, when test resistance is less than 50Ω , buzzer will sound. When it is from 50Ω to 90Ω , buzzer may or may not sound. When it is more than 90Ω , buzzer won't sound.

Non-Contact Voltage Detection

Press NCV key. Place non-contact sensor close to the conductor. When test voltage is greater than $90V$ AC (RMS) and when the meter is close to the conductor, the meter induction voltage indicator will flash and buzzer will sound.

Note:

- 1: Even there is no indication, voltage may exist. Don't use non-contact voltage detector to judge whether there is voltage in the wire. Detection operation could be affected by socket design, insulation thickness, type and other factors.

- 2: When inputting voltage on the meter input terminal, due to the existence of the induced voltage, voltage induction indicator also may light.
- 3: Interference sources of external environment (such as flashlight, motor, etc.) may trigger non-contact voltage detection by mistake.

Technical Data

General characteristics: the maximum voltage of voltage input end and ground CAT III 600V  and 600V~

Display method: LCD display with maximum of 1999

Measuring principle: double integral A/D conversion

Measuring range choice: Automatic

Measurement speed: 3 times/s

Unit display: has function and power unit symbol display
Polarity indication: display “-” symbol for negative polarity input

Overrange display: “OL”

Data hold function: display “” on the top of LCD

Low battery display: display “” on the top of LCD

Power battery: DC1.5V X3 SIZE AAA.

Outside measurement: 220mm×81mm×41mm

Weight: about 286g (include battery)

The largest size of open clamp jaw: 26mm

Operating environment: 5°C~35°C

Storage temperature: -10°C~50°C

Accuracy Indicators

Accuracy: \pm (% of reading + digits) with one year of warranty

Environment temperature: 18°C~28°C

Environment humidity: not more than 75%

Temperature coefficient: $0.1 \times \text{Accuracy} / 1^\circ\text{C}$

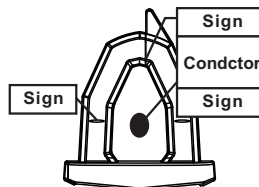

* When measuring AC current, place the conductor to be measured in the center position of clamp head. If it is not in the center position, it can increase error by 1.5%

DC Voltage

Measuring range	Resolution	Accuracy
200mV	0.1mV	$\pm(0.6\% \text{ of reading} + 3 \text{ digits})$
2V	1mV	
20V	10mV	
200V	0.1V	$\pm(0.8\% \text{ of reading} + 3 \text{ digits})$
600V	1V	

Input impedance: 10M Ω .

Maximum allowable input voltage: 600V DC or 600V AC (RMS)

AC Voltage

Measuring range	Resolution	Accuracy
200mV	0.1mV	±(0.8% of reading + 5 digits)
2V	1mV	
20V	10mV	
200V	0.1V	
600V	1V	±(1.0% of reading + 5 digits)

Input impedance: 10MΩ.

Measuring frequency range: 40Hz~400Hz.

Maximum allowable input voltage: 600V DC or 600V AC (RMS)

AC Current

Measuring range	Resolution	Accuracy
2A	0.001A	±(2.0% of reading + 5 digits)
20A	0.01A	
200A	0.1A	
600A	1A	

Measuring frequency range: 0~500A 40Hz~400Hz;
500A~600A 60Hz~400Hz.

Maximum allowable input current: AC 600A for not more than 20 seconds.

Resistance

Measuring range	Resolution	Accuracy
200Ω	0.1Ω	±(0.8% of rdg + 4digits)
2kΩ	0.001kΩ	
20kΩ	0.01kΩ	
200kΩ	0.1kΩ	
2MΩ	0.001MΩ	±(1.2% of rdg + 5digits)
20MΩ	0.01MΩ	

Overload protection: 250V DC or 250V AC (RMS)

Diode Test

Measuring range	Resolution	Accuracy
	1mV	Display approximate value of forward voltage drop (Open circuit voltage is about 1.5V)

Overload protection: 250V DC or 250V AC (RMS)

Continuity Test

Measuring range	Resolution	Accuracy
	100mΩ	The buzzer will sound when it is ≤60Ω (Open circuit voltage is about 0.45V)

Note: When resistance is from 60Ω to 90Ω, the buzzer may or may not sound. When it is more than 90Ω, the buzzer won't sound.

Overload protection: 250V DC or 250V AC (RMS)

Automatic Power-Off

In order to extend the battery life, the meter has an automatic shutdown function. If there is no key operation or function measuring range change within 15 minutes, the meter power will disconnect automatically. Press "SEL" button to return the meter to the working state again.

Replace Battery



Warning

To avoid electric shock, disconnect the probe before opening battery cover. Disconnect any circuit or signal being tested. Use only a battery with the same model or same electric specification.

If " symbol appears, it means that the battery should be replaced. Before opening the meter back cover, make sure that no probe is connected to the circuit. Check that the back cover is tightened before using the meter., Follow these steps to replace the battery:

1. Disconnect the probe and remove it from the input jack. Switch rotating function measuring range switch to "OFF".
2. Unscrew screws on the battery cover and remove the battery cover.
3. Take out the old batteries and replace with three new 1.5 V SIZE AAA batteries.
Replace the battery cover and tighten screws.

Accessories

User Manual	1 pc
Probe	1 pair
Packing box	1 pc
1.5V SIZE AAA Battery	3 pcs

