

Product name : SMA-GSM Rubber antenna-L48

1 , Products Basic Characteristics :

Model NO : ST-ANGSM-3SS	
DESCRIPTION	VALUE
Frequency range	824-960/1710-1880MHZ
Impedance	50Ω
V.S.W.R	2.0 Max
Return loss	-10dB (Max)
Gain	3dBi
Radiation	Omni-directional
Radiating element	1/4 Wave Helical
Polarization	linear Vertical
Admitted power	1W
Connector	SMA Male
Operating temp	-10°C~+60°C
Storage temp	-10°C~+70°C
Weight	About 10g

2 , Reliability Test Report

1) Environmental tests and requirements

NO	Test Item	Test methods and conditions	Test equipment	Test results
1	Temperature and humidity test	The purpose of this test program is, using detailed standard test methods to evaluate the performance from the aspects of high humidity, heat and material	K.SON INS THS-A4L-150	PASSED
		Requirement: Temp:70°C Humidity:90~95%(R.H) Time : 72H		
2	Low temperature test	Samples should be placed in a value measured by temperature, the temperature is set at -20 °C	K.SON INS THS-A4L-150	PASSED
		Requirement: Time : 24H		
3	High temperature test	Samples should be placed in a value measured by temperature, the temperature is set at 70 °C	K.SON INS THS-A4L-150	PASSED
		Requirement: Time : 24H		
4	Thermal Shock	Samples should be placed in a value measured by temperature, the temperature is set at -20~70°C	K.SON INS THS-A4L-150	PASSED
		Requirements: 8H or more. (30 minute/per,12 week period)		
5	Salt spray test	Samples should be placed in a fixed environment under its requirements: NaCL concentration: 40-60g/1Kg PH: 6.5-7.2 test: 24H	Salt spray test machine	PASSED
		1. gold-plated products are not allowed to rust and peeling 2. other nickel-plated,tin-plated, zinc products at the same shaft or rust above the surface must not have more than two points.		

2) Mechanical settings and requirements :

NO	Test Item	Test methods and conditions	Test equipment	Test results
1	Vibration test	<p>Test conditions A The purpose of this test program is, used in the standard test methods for detailed product, they exercise or move, affecting the performance of materials evaluation.</p>	Vibration testing machine	PASSED
		<p>Requirement : Vibration scope: 10-55HZ amplitude: 0.35mm acceleration amplitude: 50.0M/S sweep cycles: 30 times</p>		
2	Drop test	<p>The samples should be stored in a certain height, the height is set to 1M, follow the direction 6 fell 3 freedom.</p>	Drop test fixture	PASSED
		<p>Requirement : Mechanical characteristics of normal after the drop test.</p>		

3、SMA Specification

TECHNICAL SPECIFICATIONS :

Temp.range : -55°C ~ +155°C

Impedance : 50Ω

Frequency Range : DC ~ 12.4GHz

Working Voltage : 335Vmax

Withstand Voltage : 1000V rms

Contact resistance : Center Contact $\leq 3\text{m}\Omega$

Outer Contact $\leq 2\text{m}\Omega$

Insulation resistance : $\geq 5000\text{ m}\Omega$

VSWR : Straight ≤ 1.10

Durability : ≥ 500 cycles

MATERIAL AND PLATING :

Shell : Brass , Gold-plated

Contact pin : Brass ,Gold-plated

Socket contact : Beryllium brass , Gold-plated

Insulator : PTFE

Crimping suite : Copper alloy , Gold-plated

NO.	NAME	FINISH	Q, TY
01	Core tube	Black	01
02	SMA 180°(Male)	Nickel plating	01

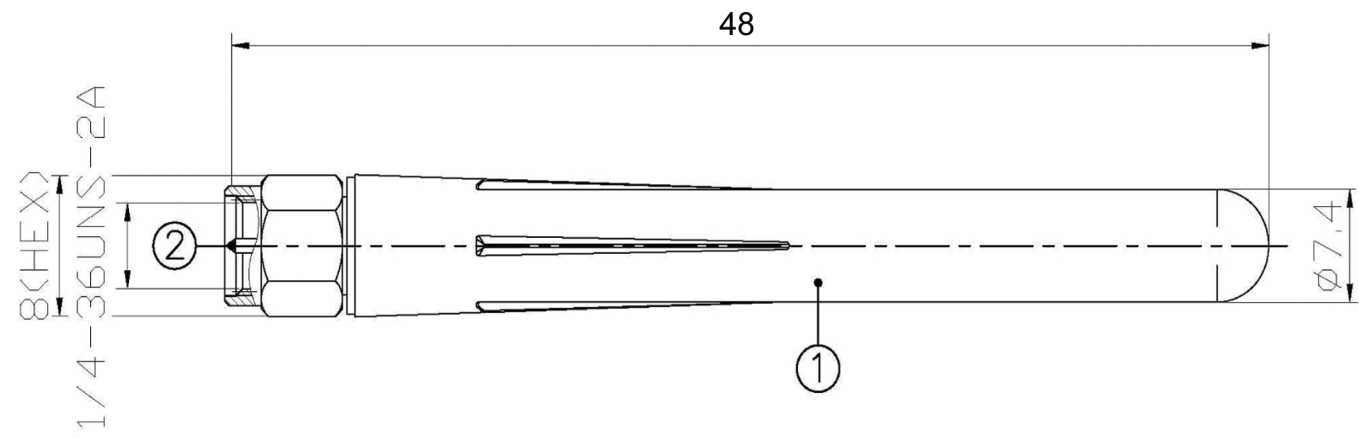
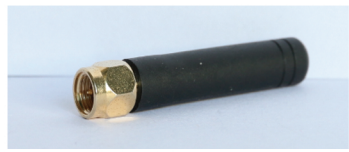

Tolerance: ±3
Weight: 10g



角法 ANGLE PROJECTION 	PRODUCT NAME				
	SMA-GSM Rubber antenna-L105				
公差 GENERAL TOLERANCE 100~200: ± 3.00 50~100: ± 2.00 25~50: ± 0.20 10~25: ± 0.10 1~10: ± 0.05 ▽: Critical Dim @: Major	PRODUCT NO	单位 (UNIT)	M M	比例 (SIZE)	FREE
	ST-ANGSM-3SS	页数 (PAGE)	1 OF 1	幅面 (FORMAT)	A4
	设计 (D S)				
	审核 (CHK)				
	核准 (APPD)				